



!!! WARUNKIEM OTRZYMANIA GWARANCJI  
JEST REJESTRACJA PRODUKTU NA STRONIE WWW.KRATKI.COM

KASETA ARKE 

INSTRUKCJA OBSŁUGI I MONTAŻU

ARKE CASSETTE / USER MANUAL AND WARRANTY CARD 

CASSETTE ARKE / MANUAL DEL USUARIO, TARJETA DE GARANTÍA 

RECUPERADOR DE CALOR ARKE / MANUAL DO UTILIZADOR E CERTIFICADO DE GARANTIA (PT) 

KAMINKASSETTE ARKE / MONTAGE- UND BEDIENUNGSANLEITUNG (D) 

ARKE CASSETTE / NÁVOD NA OBSLUHU A MONTÁŽ (S) 

CASSETTE ARKE / INSTRUCTIONS D'UTILISATION ET D'ASSEMBLAGE 

ARKE CASSETTE / INSTRUKCJA OBSŁUGI I KARTA GWARANCYJNA 

ARKE CASSETTE / GEBRUIKSAANWIJZING (NL) 

ARKE KASSETT / ANVÄNDARMANUAL (S) 

ZACHOWAJ TĘ INSTRUKCJĘ DO PRZYSZŁEGO UŻYTKU!

KEEP THIS MANUAL FOR FUTURE REFERENCE!

CONSERVE ESTE MANUAL PARA FUTURAS CONSULTAS!

GUARDE ESTE MANUAL PARA REFERÊNCIAS FUTURAS!

BEWAHREN SIE DIESE BEDIENUNGSANLEITUNG FÜR DIE WEITERE NUTZUNG AUF!

USCHOVAJTE SI TENTO NÁVOD NA POUŽITIE V BUDÚCNOSTI!

CONSERVEZ CE MANUEL POUR UNE UTILISATION ULTÉRIEURE !

CONSERVARE QUESTO MANUALE PER UN UTILIZZO FUTURO!

BEWAAR DEZE HANDLEIDING VOOR TOEKOMSTIG GEBRUIK!

SPARA DENNA BRUKSANVISNING FÖR FRAMTIDA BRUK!

THIS MANUAL, INCLUDING ALL PHOTOGRAPHS, ILLUSTRATIONS AND TRADEMARKS, IS PROTECTED BY COPYRIGHT. ALL RIGHTS RESERVED. NEITHER THIS MANUAL, NOR ANY OF THE MATERIAL CONTAINED HEREIN, MAY BE REPRODUCED WITHOUT WRITTEN PERMISSION. THE INFORMATION IN THIS DOCUMENT IS SUBJECT TO CHANGE WITHOUT NOTICE. THE MANUFACTURER RESERVES THE RIGHT TO MAKE CORRECTIONS AND CHANGES IN THIS MANUAL WITHOUT ANY OBLIGATION TO NOTIFY ANYONE ABOUT IT.

THANK YOU FOR YOUR TRUST AND PURCHASE OF THE INSERT. THIS DEVICE HAS BEEN DESIGNED FOR YOUR SAFETY AND COMFORT. WE WOULD LIKE TO EXPRESS OUR CONVICTION THAT YOU WILL BE SATISFIED WITH YOUR CHOICE BECAUSE OF THE COMMITMENT THAT WAS INVOLVED IN THE DESIGN AND PRODUCTION OF THE GAS-BURNER. PRIOR TO INSTALLATION AND USE, PLEASE CAREFULLY READ ALL OF THE CHAPTERS IN THE MANUAL. IF YOU HAVE ANY QUESTIONS OR CONCERNS, PLEASE CONTACT OUR TECHNICAL DEPARTMENT. ANY ADDITIONAL INFORMATION IS AVAILABLE ONLINE AT [WWW.KRATKI.COM](http://WWW.KRATKI.COM)

## INTRODUCTION

KRATKI.PL MAREK BAL IS A WELL-KNOWN MANUFACTURER OF HEATING EQUIPMENT IN BOTH POLAND AND EUROPE. OUR PRODUCTS ARE BASED ON STRICT STANDARDS. EACH-BURNER INSERT MANUFACTURED BY THE FACTORY IS SUBJECTED TO QUALITY CONTROL DURING WHICH IT UNDERGOES RIGOROUS SAFETY TESTS. THE USE OF THE HIGHEST QUALITY MATERIALS IN THE MANUFACTURE ENSURES SMOOTH AND RELIABLE OPERATION OF THE DEVICE BY END USERS. THIS MANUAL CONTAINS ALL OF THE INFORMATION NECESSARY FOR PROPER INSTALLATIONS, OPERATION AND MAINTENANCE OF THE INSERT.

NOTE USE PROPER WOOD AND CLEAN THE DEVICE REGULARLY. BELOW, THERE ARE SOME GUIDELINES FOR THE PROPER MAINTENANCE OF THE-BURNER INSERTS MANUFACTURED BY KRATKI.PL:

1. THE INSERT AND THE TRIM SHOULD BE INSTALLED BY QUALIFIED PERSONNEL
2. AT LEAST ONCE A YEAR, THE CHIMNEY DUCT SHOULD BE INSPECTED
3. USE DRY DECIDUOUS WOOD WITH THE MAX. MOISTURE CONTENT OF 20% FOR-BURNER
4. PRIOR TO EACH HEATING SEASON, REPLACE THE SEAL (IN THE DOOR, UNDER THE GLASS).
5. REMOVE THE ASH FROM THE ASH TRAY REGULARLY
6. DO NOT OVERHEAT THE INSERT: THE MAXIMUM LOADING IS 1/3 OF THE SIZE OF THE COMBUSTION CHAMBER
7. CLEAN THE FRONT WINDOW USING ONLY THE PREPARATIONS DEDICATED FOR THIS PURPOSE. DO NOT USE ABRASIVE PREPARATIONS AS THIS CAN RESULT IN SCRATCHING THE GLASS.
8. PLEASE NOTE THAT WHEN CLEANING THE GLASS, ALL STEEL / CAST IRON COMPONENTS EXPOSED TO CHEMICALS SHOULD BE PROTECTED. ANY CONTACT WITH SUCH SUBSTANCES CAN CAUSE CORROSION, SPLINTERS OR OTHER DAMAGE.

## INTRODUCTION

### NOTE!

THE REQUIREMENTS REGARDING THE TERMS AND CONDITIONS FOR THE INSTALLATION OF-BURNER INSERTS CAN BE FOUND IN NATIONAL STANDARDS AND IN NATIONAL AND LOCAL REGULATIONS.

THE PROVISIONS CONTAINED IN THEM MUST BE

OBSERVED!

TO AVOID THE RISK OF-BURNER, THE DEVICE MUST BE INSTALLED IN ACCORDANCE WITH THE CURRENT STANDARDS AND THE TECHNICAL REGULATIONS REFERRED TO IN THE MANUAL. ITS INSTALLATION MUST BE PERFORMED BY A PROFESSIONAL. ALWAYS OBSERVE THE REGULATIONS IN FORCE WHERE THE UNIT IS INSTALLED.

FIRST, MAKE SURE THAT THE-BURNER IS SUITABLE.

THE DEVICE MUST BE INSTALLED IN ACCORDANCE WITH THE CURRENT STANDARDS OF THE CONSTRUCTION LAW. THE INSERT MUST BE SET AT A SAFE DISTANCE FROM ANY-FLAMMABLE PRODUCTS. IT MAY BE NECESSARY TO PROTECT THE WALLS AND THE MATERIALS AROUND. THE UNIT MUST STAND ON A SOLID, NON-COMBUSTIBLE BASE. THE CHIMNEY MUST BE TIGHT, ITS WALLS SMOOTH, BEFORE CONNECTING, IT SHOULD BE CLEANED OF SOOT AND CONTAMINATION. THE CONNECTION BETWEEN THE CHIMNEY AND THE INSERT MUST BE TIGHT AND MADE OF NON-COMBUSTIBLE

MATERIALS, PROTECTED AGAINST OXIDATION (ENAMELLED OR STEEL •UE PIPE).

IF THE •UE PRODUCES WEAK DRAUGHT, CONSIDER LAYING NEW PIPES. IT IS ALSO IMPORTANT FOR THE •UE NOT TO PRODUCE EXCESSIVE DRAUGHT, YOU MUST THEN INSTALL A DRAUGHT STABILIZER IN THE •UE. ALTERNATIVELY, THERE ARE ALSO SPECIAL •UE ENDINGS REGULATING DRAUGHT. FLUE INSPECTION SHOULD BE CARRIED OUT BY A SPECIALIST AND ANY MODI•CATIONS CAN BE MADE BY AN AUTHORIZED COMPANY SO THAT THEY FUL•LLED THE REQUIREMENTS IN FORCE IN THE GIVEN COUNTRY.

#### INTENDED USE

THE •REPLACE INSERTS MANUFACTURED BY KRATKI.PL USE SOLID FUELS WITH MANUAL FEEDING FUEL AND LOCKABLE DOORS. THEY ARE DESIGNED FOR TRIMMING OR LOCATING INTO A NICHE. HARDWOOD TO BE BURNT INCLUDES: HORNBEAM, OAK, BEECH, ACACIA, ELM, MAPLE, BIRCH, WITH A MOISTURE CONTENT OF <20% (LIGNITE BRIQUETTES AND WOOD BRIQUETTES ARE ALSO ACCEPTABLE).

THEY SERVE AS AN ADDITIONAL SOURCE OF HEAT IN THE ROOMS IN WHICH THEY ARE INSTALLED.

THE HOUSING SHOULD BE DESIGNED SO THAT THE •REPLACE INSERT WAS NOT PERMANENTLY ATTACHED TO IT, WHILE RETAINING THE POSSIBILITY TO INSTALL AND REMOVE THE TRIM WITHOUT DAMAGING OR BREAKING IT. IN ADDITION, IT SHOULD PROVIDE ACCESS OF THE AIR NEEDED FOR COMBUSTION AND VENTILATION THROUGH THE USE OF SUITABLE GRILLES AND EASY ACCESS TO THE EXHAUST THROTTLE OR CHIMNEY DRAFT REGULATOR (IF INSTALLED).

#### INTRODUCTORY INFORMATION

##### NOTE!

IN ORDER TO AVOID THE DANGER OF •RE, THE •REPLACE INSERT MUST BE INSTALLED IN ACCORDANCE WITH THE RELEVANT BUILDING CODES AND THE TECHNICAL INSTRUCTIONS GIVEN IN THIS INSTALLATION AND USE MANUAL. THE DESIGN OF THE •REPLACE INSTALLATION SHOULD BE PERFORMED BY A QUALI•ED SPECIALIST. BEFORE STARTING TO USE, DEVELOP A TECHNICAL ACCEPTANCE PROTOCOL WHICH MUST BE ACCOMPANIED BY A POSITIVE OPINION OF A CHIMNEY SPECIALIST AND A •RE SPECIALIST.

- A) BEFORE INSTALLING A •REPLACE INSERT HAVE AN EXPERTISE EXECUTED AND COMMISSIONING OF THE •UE IN TERMS OF ITS TECHNICAL CHARACTERISTICS AND THE TECHNICAL CONDITION - LEAKS, BLOCKAGES.
- B) INSTALLATION AND COMMISSIONING OF THE •REPLACE INSERT SHOULD BE DONE BY AN INSTALLATION COMPANY HAVING ADEQUATE LICENSES FOR THIS PURPOSE AND EXPERIENCE.
- C) THE •REPLACE INSERT SHOULD BE LOCATED AS CLOSE TO THE •UE AS POSSIBLE. THE ROOM IN WHICH IT WILL BE INSTALLED MUST HAVE AN E•CIENT VENTILATION SYSTEM AND THE NECESSARY AMOUNT OF AIR REQUIRED FOR THE PROPER FUNCTIONING OF THE INSERT.
- D) WHILE MOVING, DO NOT GRAB THE HANDLE OF THE INSERT, AS IT MAY GET DAMAGED
- E) BEFORE USING THE INSERT, REMOVE STICKERS FROM THE GLASS
- F) ) TECHNICAL PARAMETERS OF THE INSERT APPLY TO THE FUEL SPECI•ED IN THIS MANUAL.
- G) IT IS ESSENTIAL TO COMPLY WITH •UE SERVICE INTERVALS (AT LEAST 2 TIMES A YEAR).
- H) PURSUANT TO THE CURRENT LAW, A •REPLACE CAN NOT BE THE SOLE SOURCE OF HEAT BUT IT CAN ONLY SUPPLEMENT THE EXISTING HEATING SYSTEM. THE REASON FOR THIS TYPE OF REGULATION IS THE NEED TO ENSURE THE HEATING OF THE BUILDING IN THE EVENT OF PROLONGED ABSENCE OF PEOPLE.

INSTALLATION OF A •REPLACE INSERT MUST BE CARRIED OUT IN ACCORDANCE WITH THE PROVISIONS OF STANDARDS IN FORCE IN THIS •ELD, THE REQUIREMENTS OF CONSTRUCTION LAW AND THE APPLICABLE •RE SAFETY STANDARDS. DETAILED REGULATIONS CONCERNING THE SAFETY OF CONSTRUCTION, •RE SAFETY AND THE SAFETY OF USE ARE INCLUDED IN THE REGULATIONS AND BUILDING REGULATIONS IN FORCE IN THE GIVEN COUNTRY.

#### SELECTION OF FUEL

##### FUEL RECOMMENDED

- THE MANUFACTURER RECOMMENDS USING LOGS OF SUCH DECIDUOUS TREES AS BEECH, HORNBEAM, OAK, ALDER, BIRCH, ASH, ETC. OF A LENGTH OF APPROX. 30 CM AND APPROX. 30 CM TO 50 CM IN CIRCUMFERENCE, AND LIGNITE BRIQUETTES.
- THE MOISTURE CONTENT OF THE WOOD USED FOR •RING SHOULD NOT EXCEED 20%, WHICH IS IN THE CASE OF WOOD SEASONED 2 YEARS AFTER FELLING, UNDER SHELTER.

#### FUEL NOT RECOMMENDED

YOU SHOULD AVOID LOGS OR SPLIT LOGS WITH A MOISTURE CONTENT EXCEEDING 20%, AS THIS MAY RESULT IN A FAILURE TO ACHIEVE THE DECLARED TECHNICAL PERFORMANCE - REDUCED THERMAL E•CIENCY. IT IS NOT RECOMMENDED TO USE •RING LOGS OF CONIFEROUS AND GOPHER WOOD WHICH CAUSE HEAVY SMOKE IN THE DEVICE AND THE NEED TO CLEAN THE DEVICE AND THE CHIMNEY DUCT MORE FREQUENTLY.

#### FUEL FORBIDDEN

FUEL FOR THE INSERTS CANNOT INCLUDE: MINERALS (E.G. COAL), TROPICAL WOOD, (E.G. MAHOGANY), CHEMICAL PRODUCTS OR LIQUIDS, SUCH AS OIL, ALCOHOL, BENZENE, NAPHTHALENE, LAMINATED BOARDS, IMPREGNATED OR COMPRESSED PIECES OF WOOD WITH GLUE, GARBAGE. IF OTHER FUELS ARE ALLOWED, SUCH INFORMATION WILL BE PLACED ON THE NAMEPLATE.

#### HOUSING OF THE FIREPLACE INSERT:

THE HOUSING SHOULD ALLOW ACCESS OF AIR REQUIRED FOR VENTILATION AND AIR CIRCULATION IN THE HOUSING BY APPLYING GRILLES SELECTED ACCORDING TO THE INSERT POWER (IN THE LOWER PART OF THE ENVELOPE - UNDER THE INSERT) AND AN OUTLET GRILLE (AT THE TOP OF THE ENVELOPE - OVER THE INSERT).

#### SELECTION OF GRILLES

INTAKE AND OUTLET GRILLES: IN THE LOWER PART OF THE TRIM OF A •REPLACE INSERT, PROVIDED A HOLE (S) TO SUPPLY AIR REQUIRED FOR HEATING AIR INTAKE (BOTTOM VENTILATION GRILLES). TO ENSURE PROPER EXHAUST OF HOT AIR FROM THE HOOD, PROVIDE EXHAUST HOLES IN IT WITH VENTILATION GRILLES - AIR OUTLET (UPPER VENTILATION GRILLES). HOLES •NISHED O• WITH GRILLES OF CROSS-SECTIONS DEPENDING ON THE INSERT POWER, FROM 40 TO 60 CM<sup>2</sup> PER 1 kW OF THE •REPLACE INSERT.

NOTE: BECAUSE OF THE HIGH TEMPERATURES IN THE HOUSING OF THE INSERT, THE GRILLES IN THE HOOD AND THE AIR DISTRIBUTION CROWNING THE SYSTEM IN THE HOUSE HAVE TO BE METAL. ONLY GRILLES WITHOUT BLINDS ARE ALLOWED IN THE ~REPLACE HOOD.

E•ECTIVE AREA OF THE GRILLES: THE RECOMMENDED E•ECTIVE AREA OF THE INLET / OUTLET GRILLES FOR •REPLACE INSERTS (STEEL OR CAST IRON) TO 10 kW, IT IS THE AIR INTAKE (LOWER VENTILATION GRILLES) / THE AIR OUTLET (UPPER VENTILATION GRILLES)  $CM_2 \geq 500$  CM<sup>2</sup> (E•ECTIVE AREA OF THE GRILLE OR ALL OF THE GRILLES) FOR INSERTS TO 15 kW, IT IS THE AIR INTAKE (LOWER VENTILATION GRILLES) / THE AIR OUTLET (UPPER VENTILATION GRILLES)  $CM_2 \geq 700$  CM<sup>2</sup> (E•ECTIVE AREA OF THE GRILLE OR ALL OF THE GRATES), AND FOR INSERTS OVER 15 kW, IT IS THE AIR INTAKE (LOWER VENTILATION GRILLES) / THE OUTLET AIR (UPPER VENTILATION GRILLES)  $CM_2 \geq 800 - 1200$  CM<sup>2</sup> OR MORE (E•ECTIVE AREA OF THE GRILLE OR ALL OF THE GRILLES).

DECOMPRESSION GRILLES: VERY HIGH TEMPERATURES ARE RECORDED INSIDE THE HOOD, THEREFORE, INSIDE THE HOOD, APPROX. 40 CM FROM THE CEILING OF THE ROOM, A DECOMPRESSION SHELF SHOULD BE •TTED I.E. A CEILING OVER THE INSERT. IT PREVENTS HEATING OF THE CEILING OF THE ROOM, HEAT LOSSES AND FORCES THE INSTALLATION OF PROPER EXHAUST GRILLES UNDER IT TO EMIT EXHAUST HEAT FROM THE CHAMBER ABOVE THE •REPLACE. GRILLES (DECOMPRESSION ONES) ARE MOUNTED ON BOTH SIDES OF THE HOUSING ON OPPOSITE SIDES, E.G. ALTERNATELY HIGHER AND LOWER THAN THE DECOMPRESSION SHELF. THEY ALLOW FOR INTENSIVE AIR •OW CIRCULATION THAT COOLS THE CEILING SURFACE. THE SIZE OF THE GRILLES - THEIR E•ECTIVE AREA IS NOT IMPORTANT.

#### MOUNTING AND INSTALLATION OF A FIREPLACE INSERT

INSTALLING A •REPLACE INSERT SHOULD BE PERFORMED BY A PERSON WITH LICENSES FOR PERFORMING THIS TYPE OF

ASSEMBLY WORK. IT IS A CONDITION OF SAFE USE OF THE •REPLACE INSERT. THE INSTALLER SHOULD CONFIRM THE CORRECT EXECUTION OF THE ASSEMBLY BY SIGNING THE STAMPED WARRANTY CARD. FAILING TO FULFILL THIS REQUIREMENT MAKES THE BUYER LOSE THE RIGHT UNDER THE WARRANTY CLAIMS AGAINST THE MANUFACTURER OF THE •REPLACE INSERT.

## PREPARATION FOR INSTALLATION

EVERY •REPLACE INSERT IS DELIVERED READY FOR INSTALLATION AND TRIMMING. AFTER UNPACKING, CHECK THE COMPLETENESS OF THE EQUIPMENT ACCORDING TO THIS MANUAL. ADDITIONALLY, YOU SHOULD CHECK THE OPERATION ADJUSTMENT MECHANISM;

- THE MECHANISM FOR CONTROLLING THE FLOW OF AIR INTO THE COMBUSTION CHAMBER (ASH PAN DRAWER);
- THE PROPER OPERATION MECHANISM OF THE FRONT DOOR CLOSING (HINGES, HANDLE);
- DURABILITY OF THE HOUSING OF THE FUE AND SMOKE DUCTS MUST HAVE A FIRE RESISTANCE OF AT LEAST 60 MIN.;
- INSTALLATION OF THE •REPLACE INSERT CAN BE MADE AFTER A POSITIVE RESULT OF AN EXPERTISE OF THE SMOKE DUCT;

## INSTALLATION OF A FIREPLACE INSERT

INSTALLING A •REPLACE INSERT SHOULD BE CARRIED OUT IN ACCORDANCE WITH THE RELEVANT CONSTRUCTION LAW, FIRE REGULATIONS AND GENERAL REGULATIONS, IN PARTICULAR:

- **before choosing the location of the fireplace insert, examine all issues related to its placement in terms of construction fire protection**
- **check the mechanical strength of the substrate on which the fireplace insert is to be located, taking into account total weight of insert and its**
- **the fireplace insert must be installed on a non-combustible substrate of the min. thickness of 300 mm**  
MATERIAL BELONGING TO CLASS A, B, C, D, E, F, G, H, I, J, K, L, M, N, O, P, Q, R, S, T, U, V, W, X, Y, Z, OR PROTECTED BY A CLASS A, B, C, D, E, F, G, H, I, J, K, L, M, N, O, P, Q, R, S, T, U, V, W, X, Y, Z, OR NON-COMBUSTIBLE
- **The smoke ducts must meet the basic criteria, namely:**
  - MUST BE MADE OF MATERIALS THAT WEAKLY CONDUCT HEAT;
  - FOR A •REPLACE INSERT WITH A DIAMETER OF THE FUE PIPE OF 200 MM, THE MINIMUM CROSS-SECTION MUST BE 4 DM<sup>2</sup>;
  - THE EXHAUST PIPE MUST NOT HAVE MORE THAN TWO SLOPES OF 45° TO THE HEIGHT OF 5M AND 20° AT THE HEIGHT OF MORE THAN 5 M;
- **The flue draught must be:**
  - THE MINIMAL DRAUGHT -  $6 \pm 1$  Pa;
  - THE MEAN RECOMMENDED DRAUGHT -  $12 \pm 2$  Pa;
  - THE MAXIMUM DRAUGHT -  $15 \pm 2$  Pa;
- **The mounting structure and the trim of the fireplace insert should be made of non-combustible materials, such as: CERAMIC, CERAMIC GLAZED, CERAMIC UNGLAZED, CERAMIC REINFORCED HEAT-RESISTANT PANELS, ALUMINIUM COATINGS.**

- **The principles of good circulation and air balance in the room where the fireplace is to be installed should be followed:**

- THE DISTANCE OF THE INSULATION FROM THE INSERT WALLS - 8-12 CM,
- IN ROOMS WITH MECHANICAL VENTILATION OR VERY TIGHT WINDOW JOINERY, APPLY INDIVIDUAL AIR SUPPLY TO THE COMBUSTION CHAMBER OF THE INSERT, THE INSERT MANUFACTURER RECOMMENDS THE USE OF AN INLET,
- WHEN USING AN AIR DISTRIBUTION SYSTEM TO OTHER ROOMS, IN ORDER TO OBTAIN FREE CIRCULATION OF AIR, ENSURE THAT IT COULD RETURN TO THE ROOM WHERE THE •REPLACE IS INSTALLED AFTER IT IS COOLED DOWN. FAILING TO STICK TO THIS RULE MAY DISTURB THE CYCLE OF THE INSERT AND PREVENT DISTRIBUTION OF THE HEATED AIR.

THE ROOM WHERE THE •REPLACE IS INSTALLED MUST HAVE A VOLUME OF NOT LESS THAN 30 M<sup>3</sup> AND HAVE A SUPPLY OF THE RIGHT AMOUNT OF AIR INTO THE STOVE OF THE •REPLACE.

IT IS ASSUMED THAT BURNING 1 KG OF WOOD IN THE •REPLACE WITH A CLOSED COMBUSTION CHAMBER REQUIRES APPROXIMATELY 8M<sup>3</sup> OF AIR.

THEREFORE, IT IS EXTREMELY IMPORTANT TO BRING FRESH AIR FOR COMBUSTION, PREFERABLY USING FRESH AIR INTAKE

FROM THE OUTSIDE. THIS SYSTEM ENABLES THE SUPPLY OF COLD AIR FOR THE COMBUSTION PROCESS. IN ADDITION, THE AIR SUPPLY SHOULD BE EQUIPPED WITH A THROTTLE SO THAT THE ROOM DOES NOT LOSE HEAT WHILE THE FIREPLACE IS NOT IN USE. THERE ARE TWO WAYS TO DISTRIBUTE THE HOT AIR IN THE ROOM: GRAVITATION AND FORCED.

#### GRAVITATION HOT AIR DISTRIBUTION SYSTEM

WHEN WE HEAT AN AREA OF NOT MORE THAN THE ROOM WHERE THE FIREPLACE IS AND ADJACENT ROOMS, CHOOSE THE GRAVITY SYSTEM. IN THIS CASE, HOT AIR WILL MOVE UPWARDLY INTO THE CHAMBER BY WAY OF THE HEATING PIPES, THE SO-CALLED THERMAL BUOYANCY. IF YOU IMPLEMENT THIS SYSTEM, REMEMBER TO PROPERLY INSULATE AND KEEP THE DISTRIBUTION PIPES REASONABLY SHORT (UP TO 3 METERS). AT THE SAME TIME, HOT AIR CAN NOT BE DISTRIBUTED TO TOO MANY ROOMS. IF THE DISTANCE IS MORE THAN 3 METERS FROM THE FIREPLACE, HOT AIR IS NOT ABLE TO OVERCOME RESISTANCE AND IT DOES NOT REACH THE OUTLETS OR ITS SPEED IS TOO LOW, WITH THE RESULT THAT GRAVITY FLOW IS NOT SUFFICIENT.

THE ADVANTAGE OF THIS SYSTEM ARE RELATIVELY SMALL FINANCIAL COSTS TO BE INCURRED FOR INSTALLATION. A HIGH-TEMPERATURE DEFECT THAT, IN THE ABSENCE OF PROPER FILTRATION, CAN CAUSE A VERY UNFAVOURABLE PHENOMENON OF THE PYROLYSIS OF DUST, AND THEREFORE THE SYSTEM IS LESS FREQUENTLY USED AND NOT RECOMMENDED.

#### FORCED HOT AIR DISTRIBUTION SYSTEM

THE SYSTEM REQUIRES THE INSTALLATION OF A SUPPLY DEVICE - A TURBINE THAT SUCKS HOT AIR HEATED BY THE FIREPLACE INSERT AND PUMPS IT TO ALL BRANCHES OF THE SYSTEM. THEREFORE, IN THIS CASE, A SUPPLY PIPE THAT CONNECTS THE INSERT WITH THE AIR-SUPPLY DEVICE IS USED WITH THE MAXIMUM POSSIBLE CROSS-SECTION AND THE MINIMUM LENGTH.

THE DGP INSTALLATION REQUIRES:

- ducts, pipes, passages, reducers, distribution boxes, filters, all usually made of galvanized steel;
- fireplace grates or anemostats;
- insulated flexible ducts characterized by the minimal resistance up to 250 ° C (fully non-flammable);
- supply device, e.g. a turbine.

ALL OF THE ABOVE ELEMENTS CAN BE FOUND IN OUR OFFER.

THE DGP SYSTEM INSTALLATION SHOULD BE ENTRUSTED TO A SPECIALIZED COMPANY THAT WILL DESIGN A PROPER SYSTEM OF CONNECTIONS AND THE DISTRIBUTION OF INDIVIDUAL ELEMENTS. PRIOR TO INSTALLATION OF THE INSERT AND THE DGP SYSTEM, CHECK THE HEAT DEMAND FOR THE LOCATION YOU WANT TO WARM UP AND THE REQUIRED EQUIPMENT FOR THIS PURPOSE.

FORCED SYSTEMS UNDOUBTEDLY OFFER MORE OPPORTUNITIES THAN GRAVITY SYSTEMS.

ON THE OTHER HAND, THE DISADVANTAGE IS THE MORE COMPLICATED ASSEMBLY SYSTEM AND THE COSTS RELATED TO THE OPERATION, I.E. THE CURRENT CONSUMPTION OF THE TURBINE. THESE EXPENSES, HOWEVER, ARE COMPENSATED BY SAVINGS THAT CAN BE FELT IN THE BILL FOR HEATING THE BUILDING.

THE FOLLOWING DIAGRAM SHOWS A DIAGRAM OF AN EXEMPLARY INSTALLATION AND CONNECTION TO THE CHIMNEY. (FIGURE 4)

#### SPARE PARTS

KRATKI.PL SUPPLIES SPARE PARTS FOR THE ENTIRE LIFE OF THE DEVICE. TO DO THIS, PLEASE CONTACT OUR SALES DEPARTMENT OR YOUR NEAREST POINT OF SALE.

#### MAINTENANCE OF THE FIREPLACE INSERT

MAINTENANCE ACTIVITIES OF THE FIREPLACE INSERT AND SMOKE DUCTS CONSIST OF ENSURING COMPLIANCE WITH THE FOLLOWING GUIDELINES.

PERIODIC OR ORDERED MAINTENANCE OF THE INSERT

- ash removal, cleaning the glass, cleaning the combustion chamber, cleaning the flue duct;
- leaving ash in the ash drawer for an extended period will cause chemical ash panning;
- periodic cleaning the combustion chamber of the insert (the frequency of this operation depends on

THE SPECIES OF WOOD USED      THE MOISTURE

18      AND      CONTENT);

- use a poker, scrapers and a brush to clean cast iron elements
- the front glass should be cleaned using the preparation for this purpose (do not clean the cast iron parts of the insert). DO NOT USE ABRASIVE PREPARATIONS, AS THIS WILL DAMAGE THE GLASS.
- cleaning the flue ducts should be carried out by a chimney sweeper and documented in the insert documentation (DUCT CLEANING IS TO BE PERFORMED TWICE A YEAR).

NOTE: ALL AND ANY MAINTENANCE CAN BE PERFORMED ONLY WHEN THE FIREPLACE INSERT IS FULLY COOLED DOWN WITH THE USE OF PROTECTIVE GLOVES.

## ANOMALIES IN THE OPERATION OF THE FIREPLACE INSERT

DURING OPERATION OF THE FIREPLACE INSERT, SOME ANOMALIES CAN HAPPEN, SUGGESTING IRREGULARITIES IN THE INSERT OPERATION. THIS MAY BE CAUSED BY IMPROPER INSTALLATION OF THE FIREPLACE INSERT WITHOUT STICKING TO THE EXISTING LEGISLATION OR THE PROVISIONS OF THIS MANUAL OR DUE TO EXTERNAL CAUSES, E.G. THE ENVIRONMENT. THE MOST COMMON CAUSES OF THE INSERT MALFUNCTIONS ALONG WITH THEIR SOLUTIONS ARE LISTED BELOW.

### A) SMOKE RETURN WITH THE FIREPLACE INSERT DOOR OPEN:

- TOO SUDDEN OPENING OF THE DOOR (OPEN THE DOOR SLOWLY);
- INSUFFICIENT AIR SUPPLY TO THE ROOM WHERE THE FIREPLACE INSERT IS INSTALLED (PROVIDE ADEQUATE VENTILATION IN THE ROOM OR BRING AIR INTO THE COMBUSTION CHAMBER IN ACCORDANCE WITH THE GUIDELINES IN THE MANUAL);
- ATMOSPHERIC CONDITIONS;
- TOO LITTLE CHIMNEY DRAUGHT (INSPECT THE CHIMNEY INSERT).

### B) INSUFFICIENT HEATING OR EXTINGUISHED STOVE:

- A SMALL AMOUNT OF FUEL IN THE STOVE (FILL THE STOVE ACCORDING TO THE INSTRUCTIONS);
- TOO HIGH MOISTURE CONTENT USED FOR BURNING (USE WOOD WITH A MOISTURE CONTENT OF 20%);
- TOO LITTLE CHIMNEY DRAUGHT (INSPECT THE CHIMNEY INSERT).

### C) INSUFFICIENT HEATING, DESPITE A GOOD COMBUSTION IN THE COMBUSTION CHAMBER:

- LOW-CALORIE "SOFT" WOOD (USE WOOD ACCORDING TO THE RECOMMENDATIONS IN THE MANUAL);
- TOO HIGH MOISTURE CONTENT USED FOR BURNING (USE WOOD WITH A MOISTURE CONTENT OF 20%);
- TOO CHIPPED WOOD.

### D) EXCESSIVE DIRT ON THE GLASS OF THE INSERT:

- LOW INTENSITY OF BURNING (DO NOT USE FREQUENTLY AT A VERY LOW FLAME, USE ONLY DRY WOOD AS FUEL);
- THE USE OF RESINOUS SOFTWOOD AS A FUEL (USE ONLY DRY HARDWOOD AS A FUEL, AS PROVIDED IN THE OPERATING INSTRUCTIONS OF THE INSERT .
- NO AIR CURTAIN (OPEN THE SHUTTER TO PROVIDE AIR ONTO THE GLASS)

### E) THE PROPER FUNCTIONING OF THE INSERT CAN BE DISRUPTED BY WEATHER CONDITIONS (HUMIDITY, FOG, WIND, ATMOSPHERIC PRESSURE) AND SOMETIMES ADJACENT TALL BUILDINGS. IN THE CASE OF RECURRING PROBLEMS,

NOTE: IN THE CASE OF EXCESSIVE BURNING REMAINS IN THE COMBUSTION CHAMBER (ENRICHED "REMAN" (SOOT) AND WATER VAPOUR), FORMING CREOSOTE THAT CAN IGNITE IN THE SMOKE DUCT.

IN SUCH A CASE, RAPID COMBUSTION TAKES PLACE (LARGE FLAME AND HIGH TEMPERATURE) - REFERRED TO AS THE CHIMNEY FIRE.

IN THE CASE OF SUCH A PHENOMENON:

- close the holes in the ashtray drawer, the cold air intake, and the slider holes in charge of the air curtain;
- check the correctness of closing the front insert door;
- notify the nearest fire brigade unit.

## STARTUP AND OPERATION OF THE FIREPLACE GENERAL REMARKS

FIREPLACE INSERTS ARE DESIGNED FOR BURNING WOOD WITH A MOISTURE CONTENT OF 20% AND LIGNITE BRIQUETTES. THE USE OF COAL, COKE, COAL DERIVATIVES, PLASTICS, GARBAGE, RAGS AND OTHER FLAMMABLE SUBSTANCES IS PROHIBITED.

CONDITIONALLY, IT IS PERMITTED TO BURN CERTIFIED WOOD BRIQUETTES MADE FROM SAWDUST OR PELLETS, HOWEVER IN SMALL QUANTITIES ONLY.

PRACTICAL EVALUATION OF THE MOISTURE CONTENT OF WOOD FUEL USED IS AS FOLLOWS. WOOD WHICH IS TO HAVE MOISTURE CONTENT IN THE RANGE OF 18-20% MUST BE SEASONED FOR A PERIOD OF 18-24 MONTHS OR BE SUBJECT TO DRYING. WITH THE REDUCTION OF MOISTURE IN THE WOOD, THE CALORIC VALUE INCREASES, WHICH MEANS COST SAVINGS - UP TO 30% OF THE TOTAL MASS OF WOOD NEEDED FOR ONE HEATING SEASON. USING WOOD WITH TOO HIGH MOISTURE CONTENT, EXCESSIVE CONSUMPTION OF ENERGY NEEDED TO EVAPORATE THE MOISTURE MAY BE NEEDED AND CONDENSATE MAY BE CREATED IN THE BUE OR THE COMBUSTION CHAMBER, INFLUENCING THE SPACE HEATING.

ANOTHER NEGATIVE PHENOMENON OBSERVED WITH THE USE OF WOOD WITH TOO GREAT MOISTURE CONTENT IS THE PHENOMENON OF THE GENERATION OF CREOSOTE - SLUDGE BEING DESTRUCTIVE TO CHIMNEYS, WHICH CAN CAUSE INFLAMMATION AND FIRE OF THE CHIMNEY.

THEREFORE, IT IS RECOMMENDED TO USE HARDWOOD OAK, BEECH, HORNBEAM, BIRCH. CONIFERS HAVE LOWER ENERGY VALUES AND USING THEM CAUSES INTENSE SOOT ON THE GLASS.

NOTE: DO NOT USE THE FIREPLACE INSERT WHEN IT IS NOT TRIMMED, EXCEPT FOR THE TEST FIRINGS.

### STARTING THE FIREPLACE

BEFORE TRIMMING THE FIREPLACE, CONDUCT A FEW TEST IGNITIONS, DURING WHICH YOU SHOULD CHECK THE OPERATION OF THE VENT AND OTHER MOVING PARTS OF THE INSERT. NEWLY INSTALLED FIREPLACES MUST BE OPERATED WITH THE POWER OF APPROX. 30% OF THE NOMINAL POWER IN THE FIRST TWO WEEKS OF USE, WITH THE TEMPERATURE GRADUALLY INCREASED. THIS WAY OF THE USE OF THE INSERT ENABLES GRADUAL REMOVAL OF INTERNAL STRESS, THEREBY PREVENTING THERMAL SHOCKS. THIS HAS A VERY SIGNIFICANT EFFECT ON THE LATER PERFORMANCE OF THE INSERT. DURING THE FIRST FEW STARTUPS, THE INSERT CAN EMIT THE SCENT OF ENAMEL, SILICONE SEALANT AND OTHER MATERIALS USED TO PERFORM THE INSTALLATION. THIS IS A NORMAL PHENOMENON WHICH DISAPPEARS AFTER A FEW CYCLES.

### OPERATING THE FIREPLACE

IN ORDER TO START A FIRE IN THE FIREPLACE INSERT, OPEN THE INSERT DOOR USING THE HANDLE, PLACE THE KINDLING ON THE GRILL (DRY PAPER IS RECOMMENDED), LAY SHREDDED WOOD ON IT AND THEN WOOD LOGS. WE DO NOT RECOMMEND THE USE OF SYNTHETIC FIRELIGHTERS BECAUSE THEY CONTAIN CHEMICALS WHICH CAN GIVE OFF SPECIFIC ODOURS.

THEN OPEN ALL THE INLET HOLES IN THE FRONT ASH PAN AND IGNITE THE KINDLING AND THEN CLOSE THE FRONT DOOR OF THE FIREPLACE.

NOTE: IT IS FORBIDDEN TO USE OTHER MATERIALS THAN THOSE PROVIDED IN THE INSTRUCTIONS. DO NOT USE FLAMMABLE CHEMICAL PRODUCTS TO IGNITE, SUCH AS OIL, GASOLINE, SOLVENTS AND OTHERS.

AFTER THE FIRE IS IGNITED, THE WOOD BURNING CHAMBER OF THE INSERT SHOULD BE FILLED WITH FUEL IN A WAY THAT FITS THE CHAMBER APPROPRIATELY FOR THE SPECIFIED FIRING TIME ON THE BASIS OF INDIVIDUAL EXPERIENCE. DURING BURNING, THE FIREPLACE INSERT FRONT DOOR IS TO BE CLOSED. PROLONGED MAXIMUM COMBUSTION TEMPERATURES CAN LEAD TO OVERHEATING OF CAST IRON COMPONENTS AND DAMAGE. CONSEQUENTLY, THE INTENSITY OF THE FUEL COMBUSTION PROCESS IN THE FIREPLACE INSERT SHOULD BE CONTROLLED BY THE ROTARY VENT SPEED CONTROL THAT IS IN THE BUE PIPE OF THE FIREPLACE AND THE CORRESPONDING APERTURES IN THE ASH PAN. CONTROL THE LEVEL OF ROLLING THE ASH PAN TRAY WITH ASH, AS IN THE CASE OF EXCESSIVE LEVELS, COOLING THE GRATE IS LIMITED AND THE FLOW OF COMBUSTION AIR IS LIMITED. TO EMPTY THE ASH PAN DRAWER, SLOWLY OPEN THE FRONT DOOR, PULL OUT THE DRAWER FROM THE FIREPLACE INSERT AND EMPTY IT, KEEPING IN MIND THE FIRE REGULATIONS.

NOTE: DURING ALL ACTIVITIES RELATED TO MAINTENANCE AND OPERATION OF THE INSERT, REMEMBER THAT THE PARTS OF THE INSERT MAY HAVE HIGH TEMPERATURES AND THEREFORE PROTECTIVE GLOVES SHOULD BE USED. DURING OPERATION AND USE OF THE FIREPLACE INSERT, STICK TO THE RULES THAT

- Refer to the owner's manual of the fireplace insert to strictly observe its provisions;
- The insert must be installed and ignited by an installer having appropriate qualifications;

- Do not leave things sensitive to temperature near the insert glass, do not extinguish the fire in the insert glass broken, NOT WITH •AMMABLE
- Do not allow children near the fireplace;
- The principle is that opening the front doors should be slow;
- Any repairs must be done by an installer with relevant licenses and the insert manufacturer's spare parts should be used; Any changes to the structure, the use rules without the written permission of the manufacturer are unacceptable. THE

## WARRANTY CONDITIONS

The use of the •replace insert, the connection method to the chimney and operating conditions must comply with the following instructions. It is forbidden to rework or make any changes to the structure of the •replace insert.

The manufacturer offers a 5-year warranty for smooth operation from the date of purchase of the insert. The buyer of the •replace insert is required to read the operating instructions for the •replace insert with these conditions of the guarantee, which should be confirmed with an entry in the warranty card at the time of purchase.

In the case of complaints from the •replace insert user, the user is obliged to submit a complaint protocol, the completed warranty card and the proof of purchase. The submission of such documents is necessary for the claim to be considered. Consideration of the complaint shall be made within 14 days from the date of its providing. Any alterations, modifications to the design of the insert cause immediate loss of the warranty.

### THE WARRANTY COVERS:

- cast iron elements;
- movable elements of the diaphragm control mechanisms and the ash pan crease;
- the grate and the sealing of the fireplace for a period of 1 year from the date of the purchase of the insert.
- ceramic moulds for 2 years from the time of purchase;

### THE WARRANTY SCOPE SHALL NOT COVER THE FOLLOWING:

- heat-resistant ceramics (resistant to temperatures up to 800° C);
- all defects arising due to non-compliance with the provisions of the manual and, in particular, those referring to the fuel and used;
- any defects caused during transportation from the distributor to the buyer;
- any defects caused during installation, construction and commissioning of the fireplace insert;
- damage resulting from thermal overload of the liner (related to inconsistency with the provisions of the manual of the insert).

The guarantee is extended for the period from the date of •ling the complaint to the date of the notification of the buyer of the repair being done. This time will be confirmed in the warranty card. Any damages caused by improper handling, storage, poor maintenance, incompatible with the conditions laid down in the operation and maintenance manual and due to other reasons not attributable to the manufacturer, will void the guarantee, if the damage contributed to the qualitative change of the insert.

NOTE: It is forbidden to use coal as fuel in any of the insert's manufactured by us. Burning coal in each case involves a loss of the guarantee. Any customer reporting a failure under warranty is always required to sign a declaration that they did not use coal and other fuels prohibited in our insert. If there is suspicion of the use of the above-mentioned fuels, the •replace has to be assessed to investigate the presence of prohibited substances. If the analysis shows the use of them by the customer, any rights under the guarantee are lost and the customer is obliged to cover all costs associated with the

CLAIM (INCLUDING THE COSTS OF THE EXPERTISE).

THIS WARRANTY CARD IS THE BASIS FOR THE PURCHASER TO PERFORM WARRANTY REPAIRS FREE OF CHARGE.

ANY GUARANTEE CARD WITHOUT A DATE, STAMPS, SIGNATURES, AS WELL AS INCLUDING ANY AMENDMENTS MADE BY UNAUTHORIZED PERSONS EXPIRES.

DUPLICATES OF WARRANTY CARDS ARE NOT ISSUED!!!

DEVICE SERIAL

~~NUMBER~~.....

TYPE.....

THE ABOVE PROVISIONS, CONCERNING THE GUARANTEE, IN NO WAY SUSPEND, RESTRICT OR EXCLUDE CONSUMER RIGHTS DUE TO THE LACK OF CONFORMITY UNDER THE PROVISIONS OF THE ACT OF 27 JULY 2002 ON SPECIAL CONDITIONS OF CONSUMER SALES.

IN ORDER TO CONSTANTLY IMPROVE THE QUALITY OF ITS PRODUCTS, KRATKI.PL RESERVES THE RIGHT TO MODIFY THE DEVICES WITHOUT PRIOR NOTICE.

## PRODUCT DESCRIPTION

ARKE IS A •REPLACE INSERT DESIGNED FOR YOUR CONVENIENCE AND COMFORT WHILE MAINTAINING THE HIGHEST SAFETY AND QUALITY STANDARDS, AS WELL AS COMBINING EXCEPTIONAL ELEGANCE AND AESTHETICS. ANY ADDITIONAL AND USEFUL INFORMATION, INCLUDING TECHNICAL DATA (TABLE 1), AIR CIRCULATION DIAGRAM INSIDE THE CARTRIDGE (FIG.1), GLASS REPLACEMENT DIAGRAM (FIGURE 6), DOOR REMOVAL AND REPLACEMENT DIAGRAM (FIGURE 7-12) LINING AND REPLACEMENT ACUMOTE (FIG. 13-14) CAN BE FOUND AT THE END OF THIS MANUAL. THE INSTRUCTIONS ALSO SHOW HOW TO REMOVE THE FANS (FIG. 2).

THE MAIN PART OF THE •REPLACE INSERT IS THE STEEL JACKET (1) (FIGURE 3), WHERE THE COMBUSTION CHAMBER (2) IS LOCATED. THE FRONT WALL OF THE COMBUSTION CHAMBER IS THE STEEL DOOR (3) WITH A HOMOGENEOUS HEAT-RESISTANT GLASS (4) AND A HANDLE (5). THE DOOR IS MOUNTED IN THE DOOR FRAME WITH HOOKS (6). THE COMBUSTION CHAMBER IS LINED WITH ACUMOTTE (7). THE BASE OF THE INSERT IS A TWO-LAYER •OOR (8), THE STRUCTURE OF WHICH IS SIMULTANEOUSLY AN AIR INTAKE CHAMBER. THE AIR INTAKE IS REALIZED BY MEANS OF A THROTTLE •TTED WITH A CONTROL MECHANISM (11). OVER THE DOOR, THERE IS A THROTTLE CONTROL HANDLE IN THE CENTRE OF THE DEVICE FOR AIR SUPPLY ONTO THE GLASS (THE AIR CURTAIN) (12). THE CONTROL HANDLE (11), (12) MOVED ALL THE WAY TO THE LEFT MEANS AN OPEN PRIMARY AIR SUPPLY, AND WHEN THE HANDLE IS MOVED TO THE RIGHT IT MEANS THAT THE AIR INTAKE IS CLOSED. A CAST IRON GRATE (9) IS MOUNTED AT THE BOTTOM OF THE STOVE. WASTE: ASH AND UNBURNED FUEL ARE COLLECTED IN A REMOVABLE ASH TRAY (15) UNDERNEATH THE GRATE. THE ASH LEFT IN THE COMBUSTION CHAMBER SHALL BE REMOVED WITH A DUSTPAN AND A BRUSH, A •REPLACE VACUUM CLEANER OR AN ATTACHMENT TO AN INDUSTRIAL VACUUM CLEANER. THERE IS A STEEL DE•ECTOR (10) ABOVE THE COMBUSTION CHAMBER. THE DE•ECTOR IS A LIMITER FOR THE •OW OF EXHAUST GAS, INTENSIFYING THE HEAT EXCHANGE. WHILE •RING, THE •UE GASES WASH THE WALLS OF THE COMBUSTION CHAMBER, PASS UNDER THE DE•ECTOR AND CONTINUE TO •OW INTO THE •UE PIPE (14) AND PASS THROUGH THE DUCT TO THE CHIMNEY.

ARKE CASSETTE IS EQUIPPED WITH TWO FANS WITH A TOTAL POWER OF 38 W AND A CAPACITY OF 280 M<sup>3</sup>/H (18) LOCATED BELOW THE COMBUSTION CHAMBER. THE COLD AIR FROM THE ROOM IS DIRECTED BY TURBINES ALONG THE BOTTOM, REAR AND UPPER WALLS OF THE •REPLACE (16) WHERE IT IS HEATED AND THEN DISCHARGED INTO THE ROOM BY MEANS OF THE OPENINGS ABOVE THE DOOR (17). THE UNIT ALSO HAS THE OPTION TO CONNECT TWO HOT AIR DISTRIBUTION DUCTS TO THE CONVECTION DUCT. THIS CONNECTION IS MADE BY MEANS OF TWO OPENINGS IN THE TOP OF THE •REPLACE (13). TO CONNECT THE DUCTS, YOU MUST OBTAIN THE APPROPRIATE CONNECTION COMPONENTS AVAILABLE IN THE COMPANY'S O•ER.

THE TURBINES ARE POWERED BY A 230 V MAINS OUTLET. A CABLE WITH A PLUG IS CONNECTED TO THE OUTSIDE OF THE CASSETTE HOUSING. IN THE BOTTOM RIGHT CORNER OF THE DOOR FRAME THERE IS A THREE-POSITION SWITCH 1-0-2 FOR THE CONTROL OF THE TURBINES:

1 – THE TURBINES SWITCH ON AUTOMATICALLY AND WORK AT REDUCED SPEED AFTER THE SENSOR REACHES A TEMPERATURE OF 50°C. THE SENSOR IS LOCATED BELOW THE ASH TRAY IN THE FRONT OF THE UNIT,

- 2 – THE TURBINES OPERATE CONTINUOUSLY AT REDUCED SPEED REGARDLESS OF THE CASSETTE OPERATION,  
 3 – THE TURBINES OPERATE CONTINUOUSLY AT FULL SPEED REGARDLESS OF THE CASSETTE OPERATION.

ELECTRICAL CONNECTIONS ARE MADE BY MEANS OF HIGH-TEMPERATURE CONDUCTORS, WHICH ENSURE AN ADEQUATE LEVEL OF SAFETY.

KRATKI.PL RECOMMENDS TO SET THE SWITCH TO (1) WHEN •RING IN THE CASSETTE DUE TO THE LOCATION OF THE SENSOR (TEMP 50°C IS OBTAINED ONLY DURING INTENSE •RING). THE CASSETTE MUST NOT BE OPERATED WITHOUT POWER SUPPLY. (FIGURE 2)

THE ELECTRICAL INSTALLATION IS PROTECTED AGAINST THE E•FFECTS OF A SHORT CIRCUIT BY A 630 mA TUBE FUSE. THE FUSE IS INSTALLED IN THE SOCKET UNDER THE COVER.

TO REMOVE THIS ELEMENT - UNSCREW THE PLASTIC PLUG OF THE FUSE HOLDER BY TURNING IT COUNTER-CLOCKWISE.

NOTE!!!

TO DISMANTLE THE TURBINE, ~RST REMOVE THE PLUG FROM THE SOCKET.

#### PARAMETERS

GENERAL CHARACTERISTICS	ARKE 70	ARKE 75	ARKE 80	ARKE 95
NOMINAL POWER	8 kW	8 kW	12 kW	14 kW
POWER RANGE	3,5 - 10 kW	4 - 11 kW	6 - 16 kW	6 - 16,5 kW
FLUE DIAMETER	150	150	200	200
THERMAL EFFICIENCY	84 %	83 %	75 %	83 %
CO EMISSION (AT 13% O <sub>2</sub> )	0,09 %	0,10 %	0,10 %	0,10 %
DUST EMISSION	39 MG/NM <sub>3</sub>	39 MG/NM <sub>3</sub>	34 MG/NM <sub>3</sub>	38 MG/NM <sub>3</sub>
WEIGHT	110	115	132	154
NO HAZARDOUS SUBSTANCES. NO PART OF THE •REPLACE CONTAINS ASBESTOS. THE MANUFACTURE PROCESS MAKES USE OF NO CADMIUM NOR ANY HEAVY METALS.				

## ACUMOTTE

ACUMOTTE IS A SPECIAL CHAMOTTE-CONCRETE MIXTURE THAT WE USE TO LAY THE COMBUSTION CHAMBER IN OUR •REPLACE INSERTS. IT IS INTENDED PRIMARILY TO PROVIDE BETTER HEAT ACCUMULATION AND RAISE THE TEMPERATURE INSIDE THE •REPLACE. IT ALSO CONTRIBUTES TO THE BETTER COMBUSTION OF COMBUSTIBLE SUBSTANCES (E.G. WOOD GASES). THIS THEREFORE CONTRIBUTES TO MORE E•ICIENT, MORE ECO-FRIENDLY COMBUSTION AND KEEPING TEMPERATURE LONGER.

### FIRST •RING-UP

WHEN PREPARING THE •REPLACE INSERT FOR THE •RST •RING-UP, WE MUST REMEMBER TO THOROUGHLY CHECK THAT ALL ACUMOTTE ELEMENTS ARE PROPERLY AND SAFELY POSITIONED IN THE COMBUSTION CHAMBER. REMEMBER THAT A NEWLY PURCHASED INSERT IS OFTEN CHILLED. THE MATERIALS USED TO BUILD THE •REPLACE MUST SLOWLY ADJUST TO HIGH TEMPERATURES. ACUMOTTE ITSELF ALSO NEEDS TIME TO ADJUST TO THE AND ACHIEVE AN ADEQUATE LEVEL OF DRYING. THEREFORE, THE •RST TIME YOU •RE-UP, KEEP THE FURNACE TEMPERATURE RELATIVELY LOW (THIS CAN BE ACHIEVED BY FREQUENT ADDING SMALL AMOUNTS OF FUEL).



### BE CAREFUL WITH ACUMOTTE

ACUMOTTE IS A FRAGILE MATERIAL THAT IS PRONE TO FREQUENT MECHANICAL DAMAGE. THAT IS WHY WE HAVE TO DEAL WITH IT PROPERLY.

REMEMBER TO HANDLE LOGS VERY CAREFULLY, THEY SHOULD NOT HIT THE FURNACE LINING. WE WILL THEN MINIMIZE THE RISK OF DAMAGING IT.

### DOES CRACKED ACUMOTTE LOSE ITS PROPERTIES?

ONCE A SLIGHT CRACK HAS BEEN NOTED ON THE CERAMIC LINING (E.G. THE SO-CALLED HAIRLINE CRACKS), THIS IS NOT A REASON FOR ITS IMMEDIATE REPLACEMENT. ACUMOTTE DOES NOT LOSE ITS PROPERTIES. IT STILL FUNCTIONS IN THE SAME WAY AND HAS NO NEGATIVE IMPACT ON THE COMBUSTION PROCESS.

REMEMBER, HOWEVER, THAT THE LINING CAN NOT BE PUNCTURED TO THE STEEL BODY (IN THIS CASE, ACUMOTTE SHOULD BE REPLACED).

### ACUMOTTE IS ALSO CONSUMED

THE LINING OF THE COMBUSTION CHAMBER, LIKE MOST CONSUMABLES, WEARS OUT, AND AFTER A WHILE WE HAVE TO REPLACE IT. IT IS PRIMARILY THE WAY OF •RING IN THE •REPLACE THAT DETERMINES HOW QUICKLY THE LINING WEARS.

WE CAN KEEP IT IN GOOD CONDITION AS LONG AS POSSIBLE:

USE ONLY SEASONED WOOD WITH A MOISTURE CONTENT BELOW 20%.

DELICATELY INSERT (NOT THROW!) THE LOGS SO AS NOT TO DAMAGE THE CERAMIC LINING, ADD FUEL IN THE GRATE PHASE RATHER THAN DURING REGULAR •RING. THIS WILL ENABLE AVOIDING HIGH AMPLITUDE OF TEMPERATURES (IT CAN RESULT IN ACUMOTTE DAMAGE)

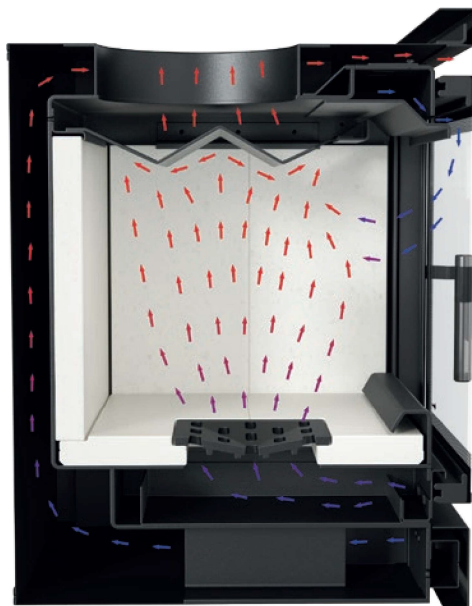

RYS. 1. KASETA ARKE – OBIEG POWIETRZA WE WKŁADZIE KOMINKOWYM ARKE

FIG. 1. ARKE INSERT - AIR CIRCULATION IN THE •REPLACE INSERT ARKE

•GURA 1. INSERT ARKE - CIRCULACIÓN DEL AIRE EN EL ARKE.

FIG. 1 - RECUPERADOR DE CALOR ARKE - CIRCULAÇÃO DO AR NO RECUPERADOR DE CALOR ARKE

ABB. 1. ARKE CASSETTE – LUFTZIRKULATION IM KAMINEINSATZ ARKE

OBR. 1 CÍRKULÁCIA VZDUCHU V KRBOVEJ VLOŽKE ARKE

FIG. 1 CASSETTE ARKE - CIRCULATION DE L'AIR DANS L'INSERT ARKE

FIG. 1. CASSETTA ARKE - CIRCOLAZIONE DELL'ARIA NELL'INSERTO PER CAMINO ARKE

AFB. 1. ARKE-CASSETTE - LUCHTCIRCULATIE IN DE ARKE-HAARDINZET

FIG. 1. ARKE KASSETT - LUFTCIRKULATION I ARKE ELDSTADSINSATS

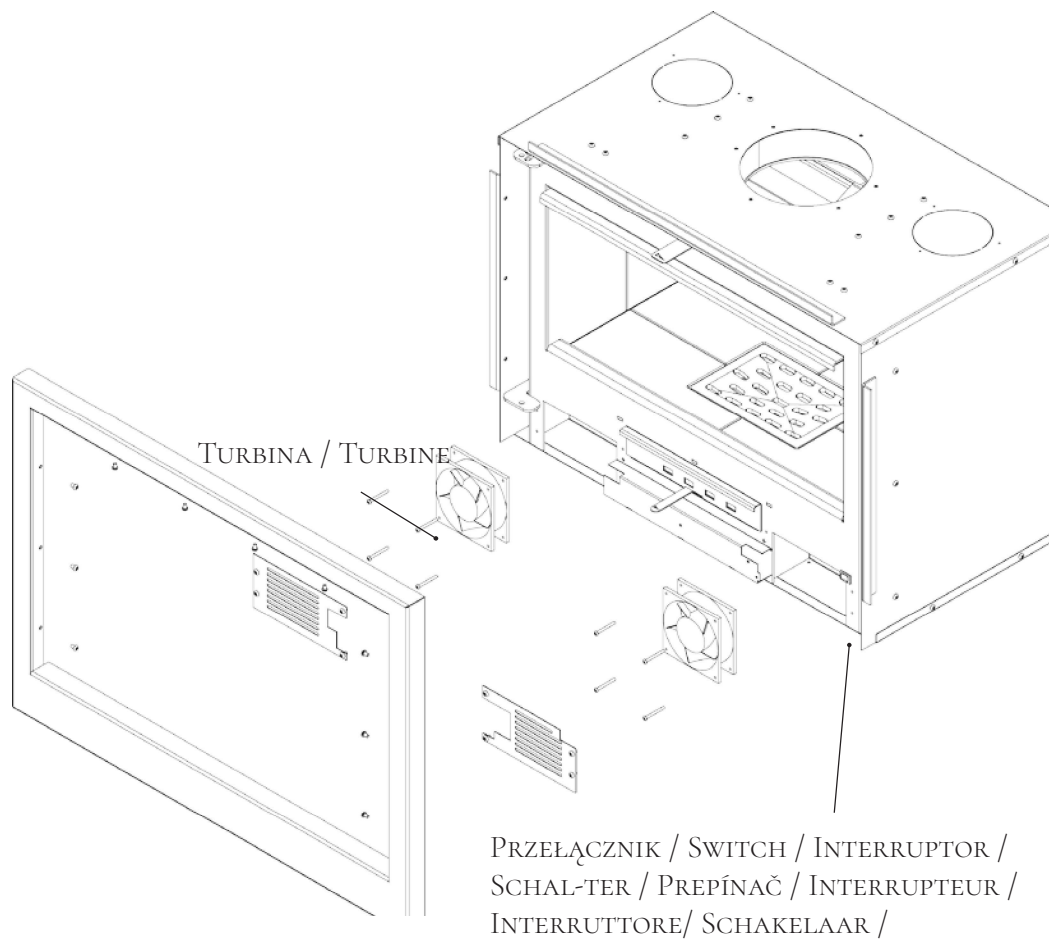

Rys. 2. KASETA ARKE – SPOSÓB MONTAŻU WENTYLATORÓW WRAZ Z UMIEJSCOWIENIEM PRZEŁĄCZNIKA

FIG. 2. ARKE CASSETTE - MOUNTING METHOD OF THE FANS ALONG WITH THE LOCATION OF SWITCH

FIG 2. INSERT ARKE - MÉTODO DE MONTAJE DE LOS VENTILADORES JUNTO CON LA UBICACIÓN DEL INTERRUPTOR

FIG. 2 - RECUPERADOR DE CALOR ARKE - MÉTODO DE MONTAGEM DOS VENTILADORES E A LOCALIZAÇÃO DO INTERRUPTOR

ABB. 2. ARKE KASSETTE – MONTAGEART DER GEBLÄSE SAMT PLATZIERUNG DES SCHALTERS

OBR. 2. KAZETA ARKE - SPÔSOB MONTÁŽE VENTILÁTOROV VRÁTANE UMIESTNENIA SPÍNAČA

FIG. 2 : CASSETTE ARKE - COMMENT LES VENTILATEURS SONT MONTÉS, Y COMPRIS L'EMPLACEMENT DE L'INTER-RUPTEUR

FIG. 2. CASSETTA ARKE - METODO DI ASSEMBLAGGIO DELLA VENTOLA INSIEME ALLA POSIZIONE DELL'INTERRUTTORE

FIGUUR 2. ARKE-CASSETTE - VENTILATORMONTAGEMETHODE SAMEN MET SCHAKELAARLOCATIE

FIG. 2. ARKE-KASSETT - •ÄKTMONTERINGSMETOD TILLSAMMANS MED STRÖMBRYTARENS PLACERING



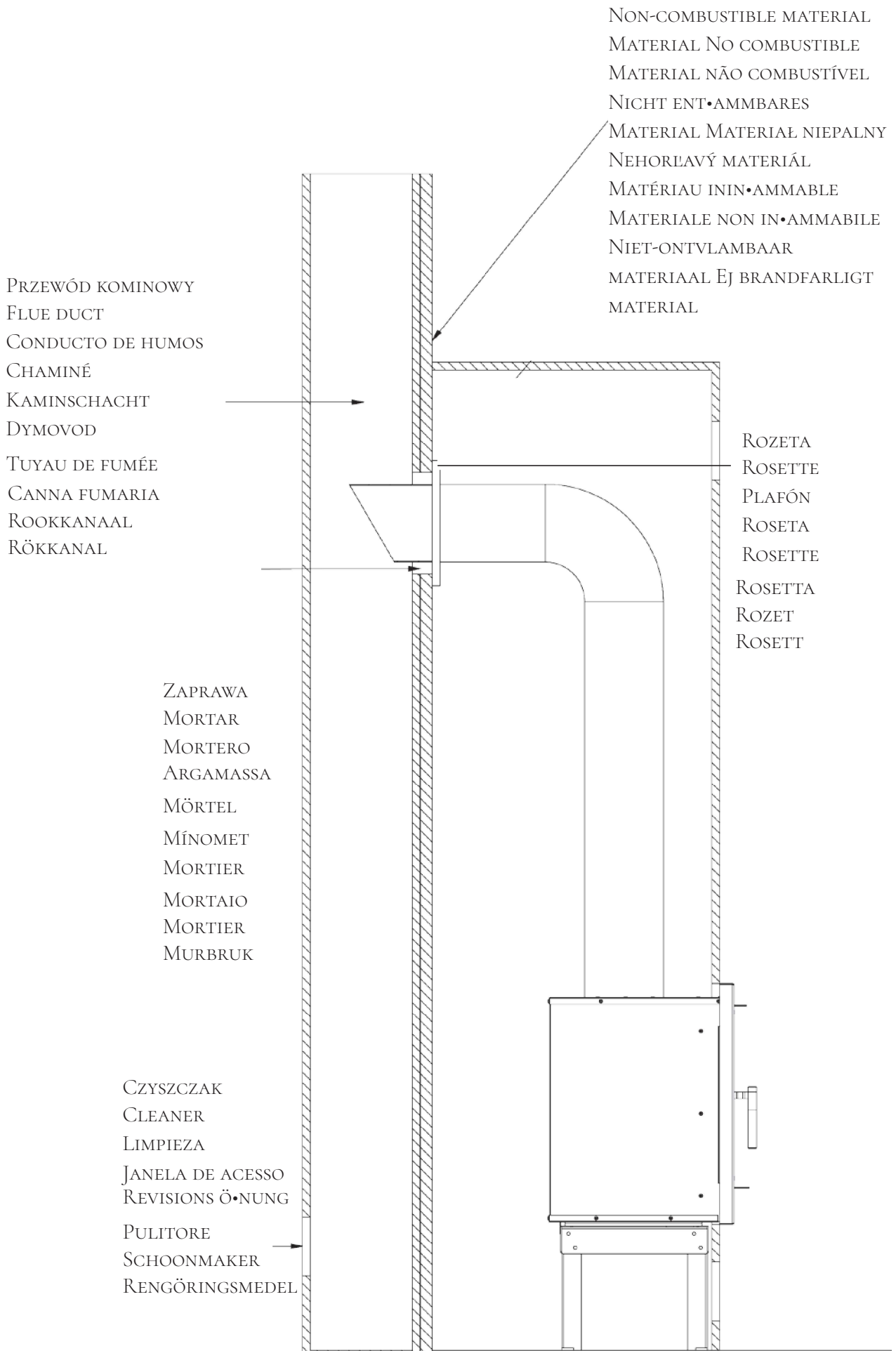

RYS. 4. KASETA ARKE – PRZYKŁADOWE PODŁĄCZENIE DO KOMINA

FIG. 4. ARKE CASSETTE - EXEMPLARY CONNECTION TO THE CHIMNEY

FIG. 4. CASSETE ARKE . EJEMPLO DE CONEXIÓN A LA CHIMENEA

FIG. 4 - RECUPERADOR DE CALOR ARKE - EXEMPLO DE LIGAÇÃO À CHAMINÉ

ABB. 4. ARKE KASSETTE – BEISPIELWEISER KAMINANSCHLUSS

RYS. 4. KASETA ARKE – PRZYKŁADOWE PODŁĄCZENIE DO KOMINA

FIG. 4 CASSETTE ARKE - EXEMPLE DE RACCORDEMENT À LA CHEMINÉE

FIG. 4. CASSETTA ARKE - ESEMPIO DI COLLEGAMENTO AL CAMINO

AFB. 4. ARKE-CASSETTE - VOORBEELD VAN AANSLUITING OP DE SCHOORSTEEN

FIG. 4. ARKE-KASSETT - EXEMPEL PÅ ANSLUTNING TILL SKORSTENEN

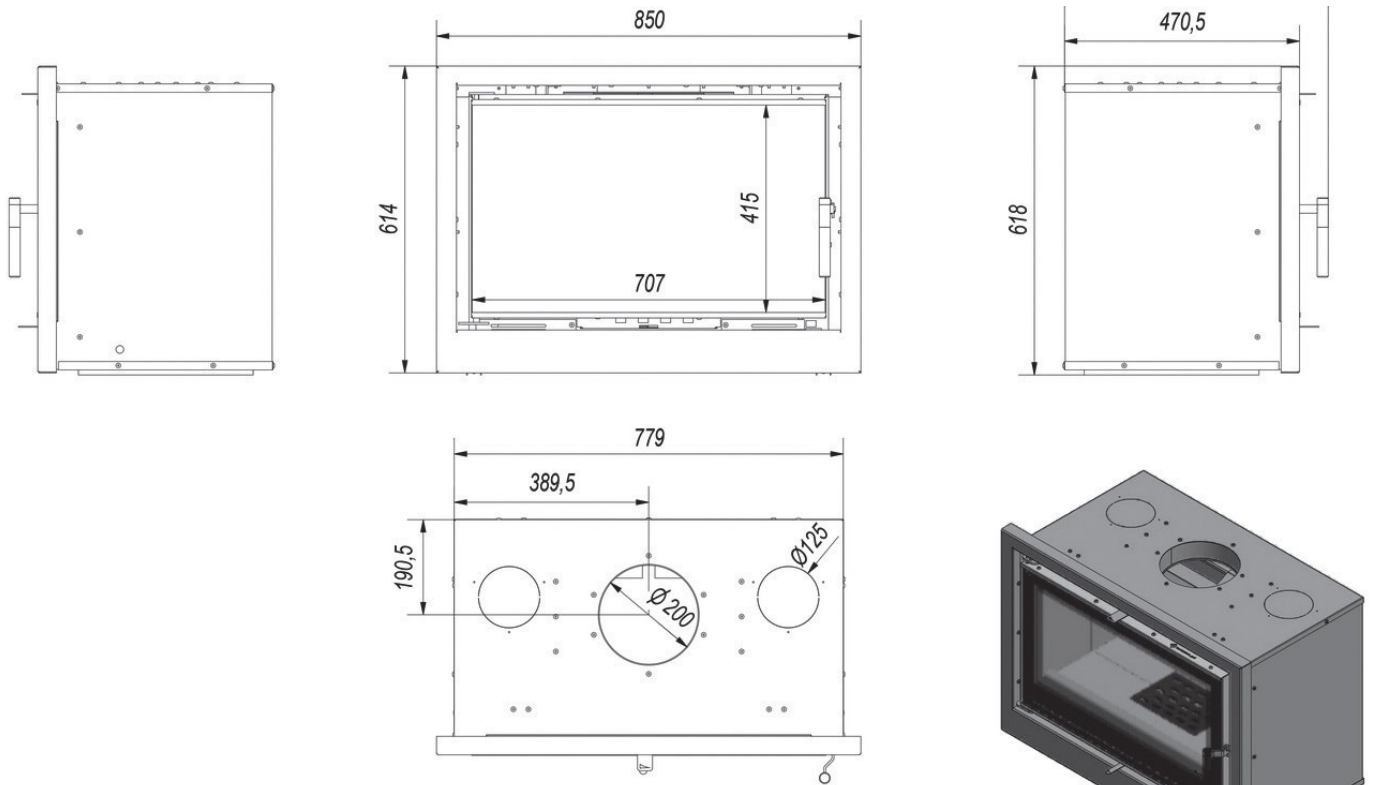

RYS. 5. KASETA ARKE - WYMIARY

FIG. 5. ARKE CASSETTE – DIMENSIONES

ABB. 5. ARKE KASSETTE – ABMESSUNGEN

FIG. 5 CASSETTE ARKE - DIMENSIONS

FIG. 5. ARKE CASSETTE - DIMENSIONS

FIG. 5 - RECUPERADOR DE CALOR ARKE - DIMENSÕES

OBR. 5 KAZETA ARKE - ROZMERY

FIG. 5. CASSETTA ARKE - DIMENSIONI

AFB. 5. ARKE-CASSETTE - AFMETINGEN

FIG. 5. ARKE-KASSETT - MÅTT

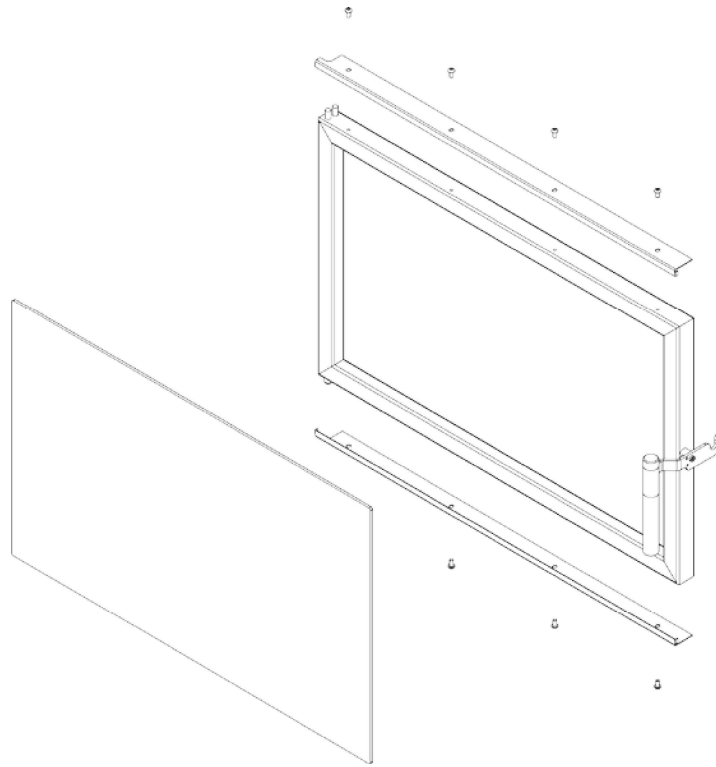

RYS. 6. KASETA ARKE – DEMONTAŻ SZYBY

FIG. 6. ARKE CASSETTE - DISMANTLING THE GLASS

RYS. 6. KASETA ARKE – DESMONTAR EL CRISTAL

FIG. 6 - RECUPERADOR DE CALOR ARKE - DESMONTAGEM DA VIDRO

ABB. 6. ARKE KASSETTE – DEMONTAGE DER SCHEIBE

OBR. 6. KAZETA ARKE - ODSTRÁNENIE SKLA

FIG. 6 CASSETTE ARKE - RETRAIT DU VERRE

FIG. 6. CASSETTA ARKE - SMONTAGGIO VETRO

AFB. 6. ARKE-CASSETTE - GLASDEMONTAGE

FIG. 6. ARKE-KASSETT - DEMONTERING AV GLAS

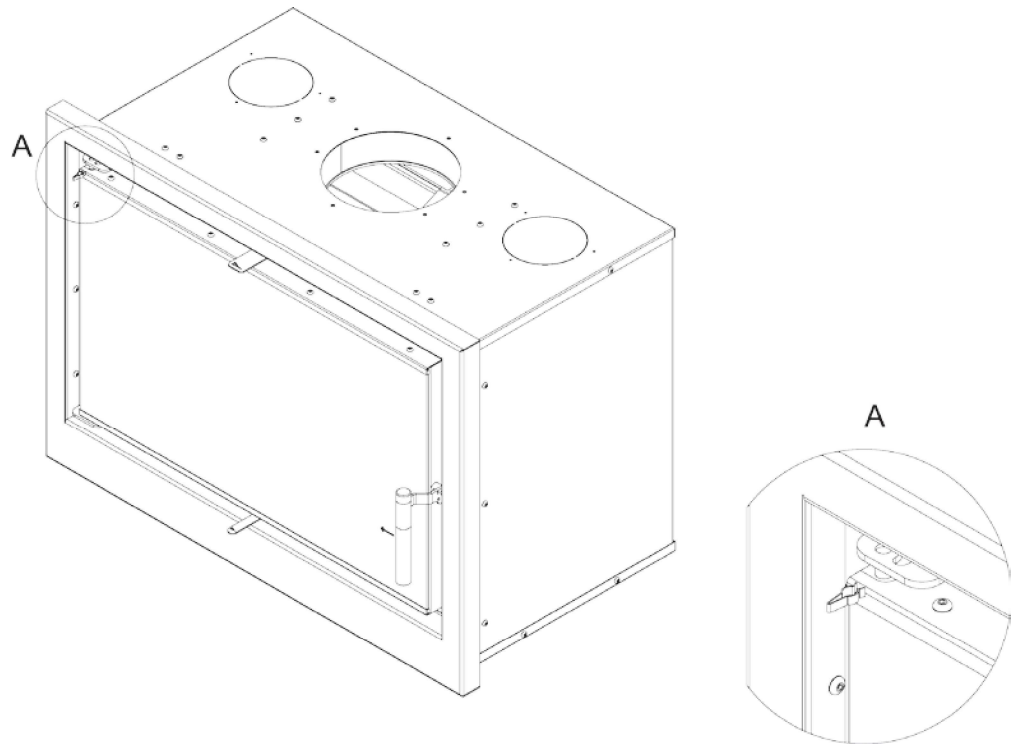

RYS. 7. KASETA ARKE – DEMONTAŻ DRZWI KROK 1 125

FIG. 7. ARKE CASSETTE - DISMANTLING THE DOOR, STEP 1

FIG. 7. ARKE CASSETTE – DESMONTAJE DE LA PUERTA, PASO 1

FIG. 7 - RECUPERADOR DE CALOR ARKE - DESMONTAGEM DA PORTA, PASSO 1

ABB. 7. ARKE KASSETTE – DEMONTAGE DER TÜR SCHRITT 1

OBR. 7 KAZETA ARKE - DEMONTÁŽ DVERÍ KROK 1

FIG. 7 CASSETTE ARKE - RETRAIT DE LA PORTE, ÉTAPE 1

FIG. 7. CASSETTA ARKE - SMONTAGGIO PORTA FASE 1

AFB. 7. ARKE-CASSETTE - DEUR DEMONTAGE STAP 1

FIG. 7. ARKE-KASSETT - DÖRRDEMONTIERUNG STEG 1

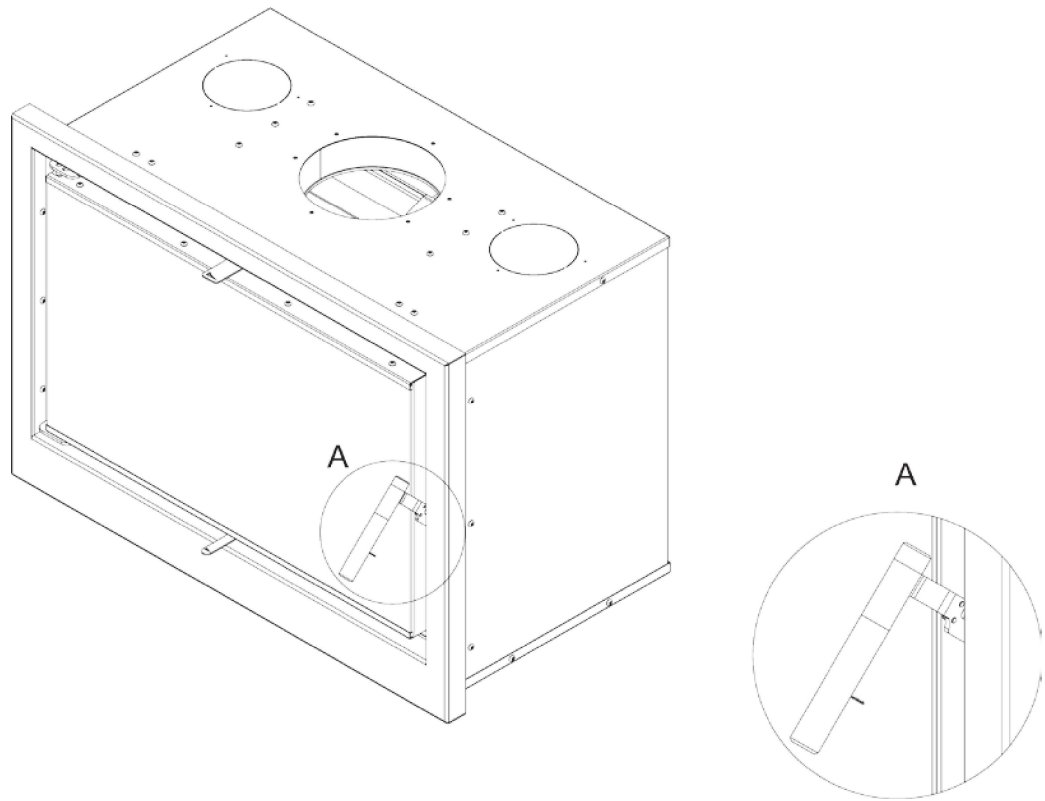

RYS. 8. KASETA ARKE – DEMONTAŻ DRZWI KROK 2

FIG. 8. ARKE CASSETTE - DISMANTLING THE DOOR, STEP 2

FIG. 8. ARKE CASSETTE – DESMONTAJE DE LA PUERTA PASO 2

FIG. 8 - RECUPERADOR DE CALOR ARKE - DESMONTAGEM DA PORTA, PASSO 2

ABB. 8. ARKE KASSETTE – DEMONTAGE DER TÜR SCHRITT 2

OBR. 8 KAZETA ARKE - DEMONTÁŽ DVERÍ KROK 2

FIG. 8 CASSETTE ARKE - RETRAIT DE LA PORTE ÉTAPE 2

FIG. 8. CASSETTA ARKE - SMONTAGGIO PORTA FASE 2

AFB. 8. ARKE-CASSETTE - DEUR DEMONTAGE STAP 2

FIG. 8. ARKE-KASSETT - DÖRRDEMONTERING STEG 2

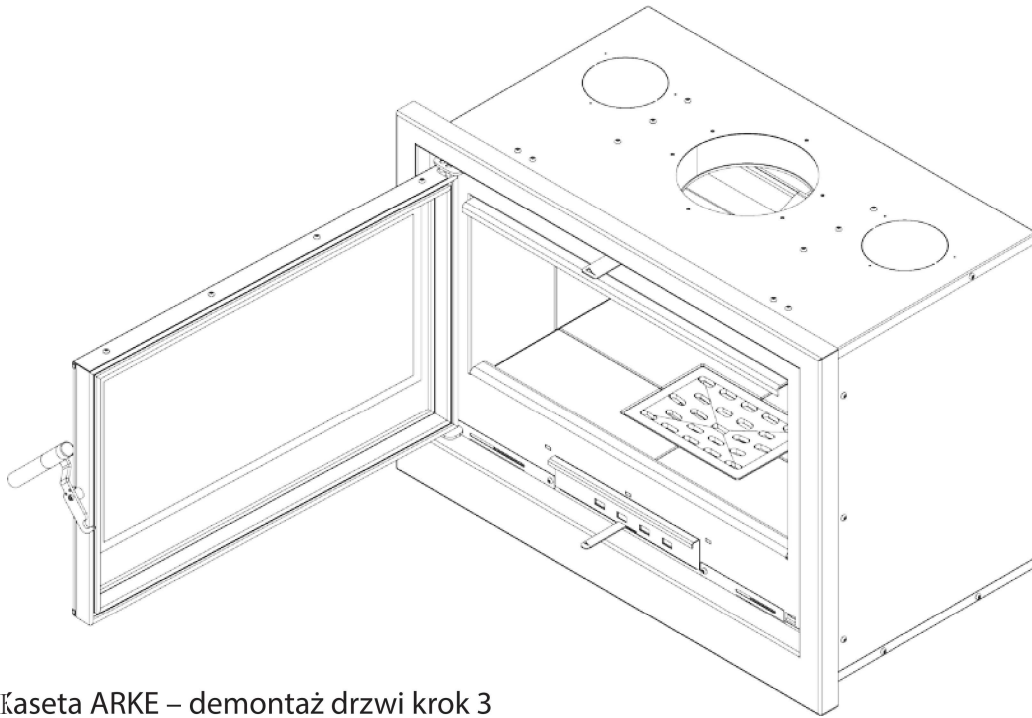

RYS. 9. Kasetta ARKE – demontaż drzwi krok 3

FIG. 9. ARKE CASSETTE - DISMANTLING THE DOOR, STEP 3

FIG. 9. ARKE CASSETTE – DESMONTAJE DE LA PUERTA PASO 3

FIG. 9 - RECUPERADOR DE CALOR ARKE - DESMONTAGEM DA PORTA, PASSO 3

ABB. 9. ARKE KASSETTE – DEMONTAGE DER TÜR SCHRITT 3

OBR. 9 KAZETA ARKE - DEMONTÁŽ DVERÍ KROK 3

FIG. 9 CASSETTE ARKE - RETRAIT DE LA PORTE ÉTAPE 3

FIG. 9. CASSETTA ARKE - SMONTAGGIO PORTA FASE 3

AFB. 9. ARKE CASSETTE - DEUR DEMONTAGE STAP 3

FIG. 9. ARKE-KASSETT - DÖRRDEMONTERING STEG 3

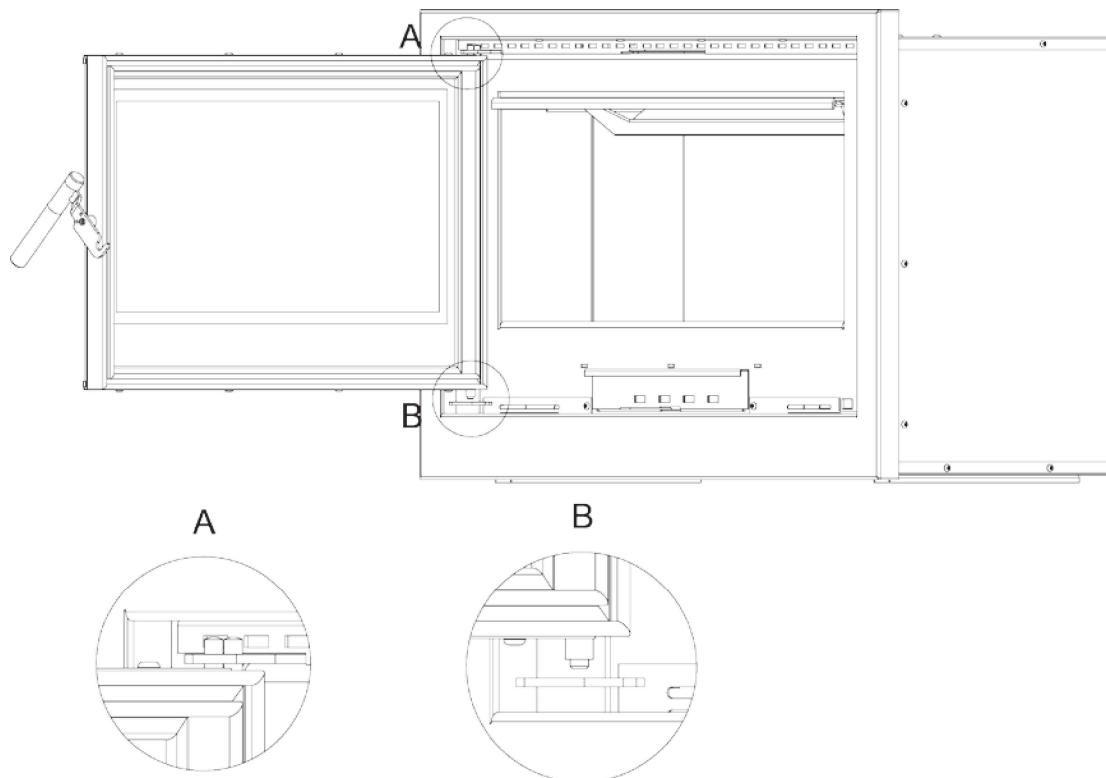

RYS. 10. KASETA ARKE – DEMONTAŻ DRZWI KROK 4

FIG. 10. ARKE CASSETTE - DISMANTLING THE DOOR, STEP 4

FIG. 10. ARKE CASSETTE - DESMONTAJE DE LA PUERTA PASO 4.

FIG. 10 - RECUPERADOR DE CALOR ARKE - DESMONTAGEM DA PORTA, PASSO 4

ABB. 10. ARKE KASSETTE – DEMONTAGE DER TÜR SCHRITT 4

OBR. 10 KAZETA ARKE - DEMONTÁŽ DVERÍ KROK 4

FIG. 10 CASSETTE ARKE - RETRAIT DE LA PORTE ÉTAPE 4

FIG. 10. CASSETTA ARKE - SMONTAGGIO PORTA FASE 4

AFB. 10. ARKE CASSETTE - DEUR DEMONTAGE STAP 4

FIG. 10. ARKE-KASSETT - DÖRRDEMONTERING STEG 4

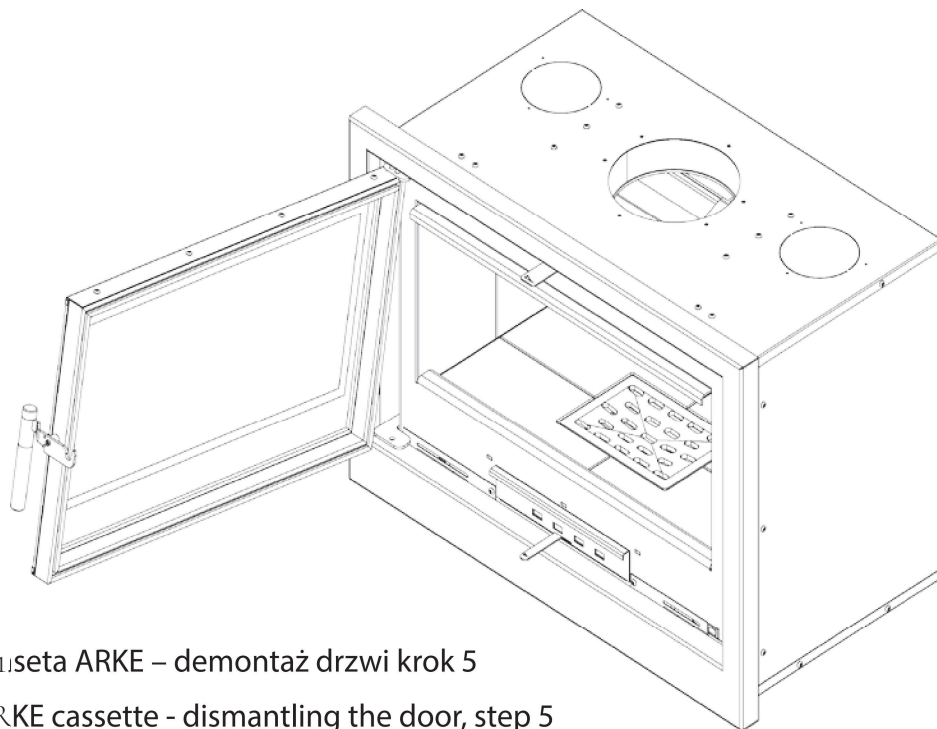

129 Rys. 11iseta ARKE – demontaž drzwi krok 5

FIG. 11. ARKE cassette - dismantling the door, step 5

FIG. 11. ARKE CASSETTE – DESMONTAJE DE LA PUERTA PASO 5

FIG. 11 - RECUPERADOR DE CALOR ARKE - DESMONTAGEM DA PORTA, PASSO 5

ABB. 11. ARKE KASSETTE – DEMONTAGE DER TÜR SCHRITT 5

OBR. 11. KAZETA ARKE - KROK 5 DEMONTÁŽE DVIEROK

FIG. 11 CASSETTE ARKE - RETRAIT DE LA PORTE ÉTAPE 5

FIG. 11. CASSETTA ARKE - SMONTAGGIO PORTA FASE 5

AFB. 11. ARKE-CASSETTE - DEUR DEMONTAGE STAP 5

FIG. 11. ARKE-KASSETT - DÖRRDEMONTIERUNG STEG 5

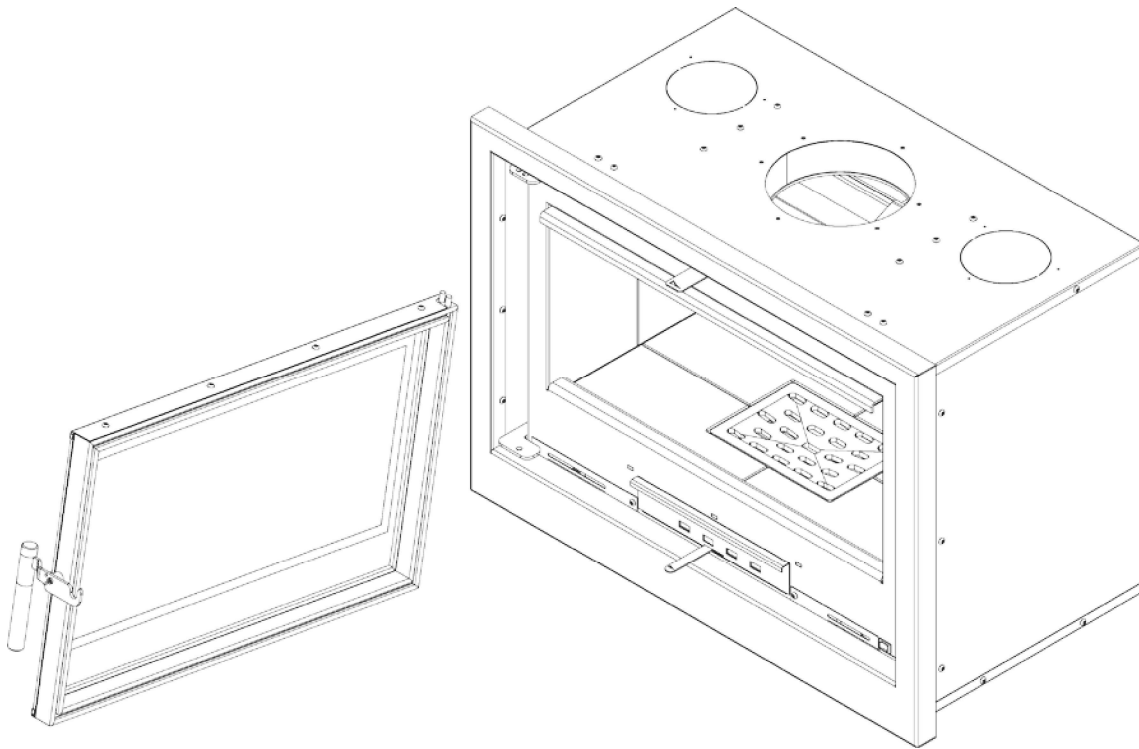

RYS. 12. KASETA ARKE – DEMONTAŻ DRZWI KROK 6

FIG. 12. ARKE CASSETTE - DISMANTLING THE DOOR, STEP 6

FIG. 12. ARKE CASSETTE – DESMONTAJE DE LA PUERTA PASO 6

FIG. 12 - RECUPERADOR DE CALOR ARKE - DESMONTAGEM DA PORTA, PASSO 6

ABB. 12. ARKE KASSETTE – DEMONTAGE DER TÜR SCHRITT 6

OBR. 12 KAZETA ARKE - DEMONTÁŽ DVERÍ KROK 6

FIG. 12 CASSETTE ARKE - RETRAIT DE LA PORTE ÉTAPE 6

FIG. 12. CASSETTA ARKE – SMONTAGGIO PORTA FASE 6

AFB. 12. ARKE CASSETTE – DEUR DEMONTAGE STAP 6

FIG. 12. ARKE-KASSETT – DÖRRDEMONTIERUNG STEG 6

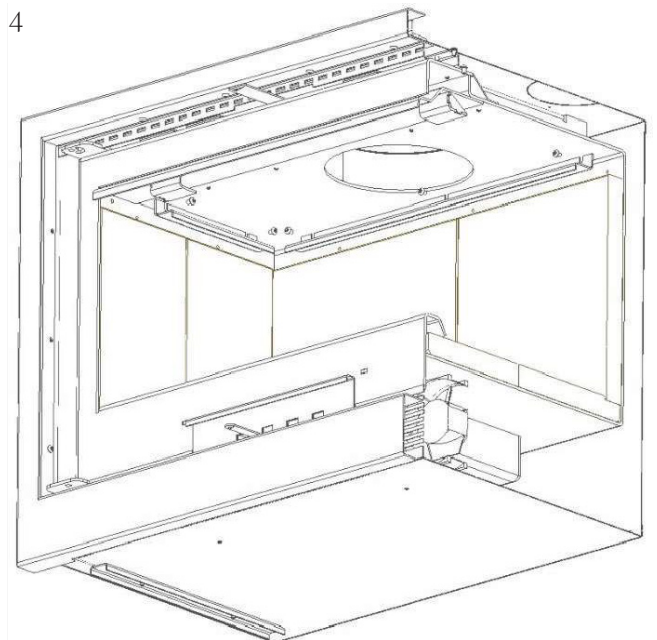
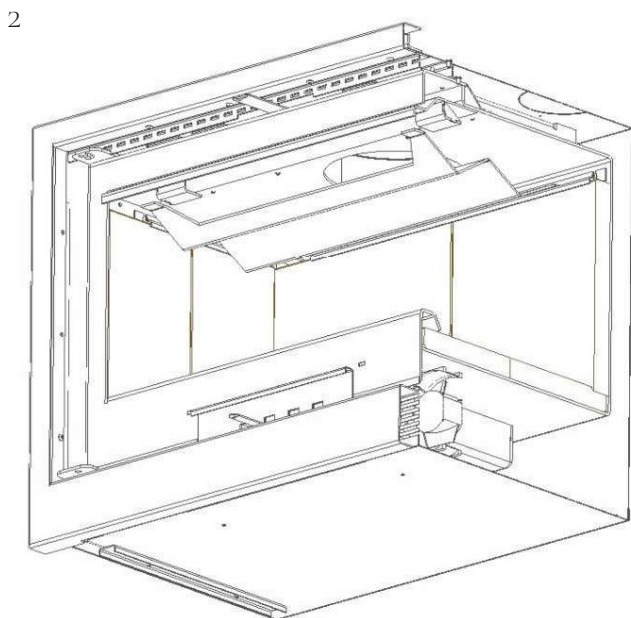
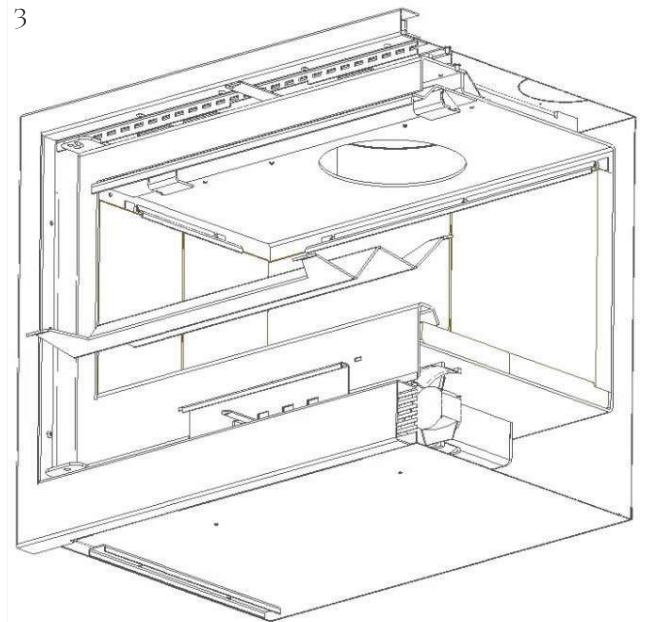
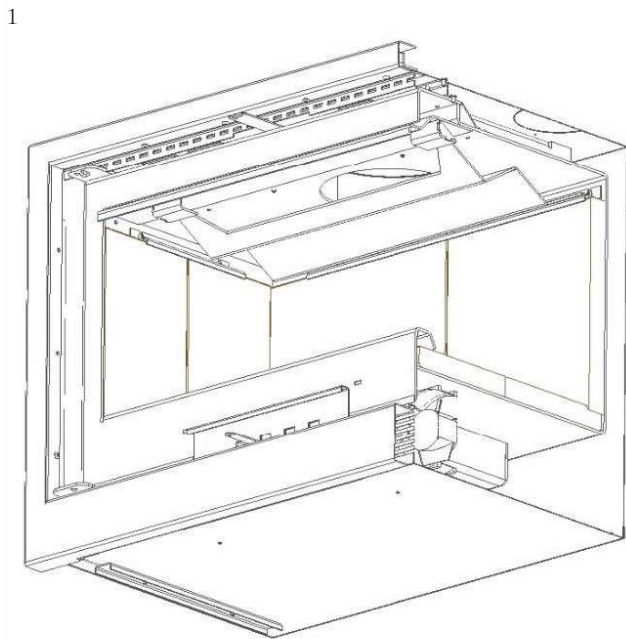

RYS. 13. KASETA ARKE – DEMONTAŽ DE•EKTORA I LISTEW TRZYMAJĄCYCH ACCUMOTE

FIG. 13. ARKE CASSETTE - DISMANTLING THE DE•ECTOR AND THE SLATS HOLDING THE ACCUMOTE

FIG. 13. CASSETTE ARKE – DESMONTAJE DEL DE•ECTOR Y LISTONES DE SUJECIÓN DEL ACCUMOTE

FIG. 13 - RECUPERADOR DE CALOR ARKE - DESMONTAGEM DO DE•ETOR E DAS LÂMINAS QUE SUPORTAM O ACU-MOTTE

ABB. 13. ARKE KASSETTE – DEMONTAGE DES DE•EKTORS UND DER HALTELEISTEN VON ACCUMOTE

OBR. 13. KAZETA ARKE - ODSTRÁNENIE DE•EKTORA A UPEVŇOVACÍCH LÍŠT ACCUMOTE

FIG. 13 CASSETTE ARKE - RETRAIT DU DÉ•ECTEUR ET DES BANDES DE MAINTIEN DE L'ACCUMOTE

FIG. 13. CASSETTA ARKE - SMONTAGGIO DEL DE•ETTORE E DELLE STRISCE DI SUPPORTO ACCUMOTE

AFB. 13. ARKE-CASSETTE - DEMONTAGE VAN DE DE•ECTOR EN ACCUMOTE-VASTHOUDSTRIPS

FIG. 13. ARKE-KASSETT - DEMONTERING AV DE•EKTORN OCH ACCUMOTE-HÅLLREMSORNA

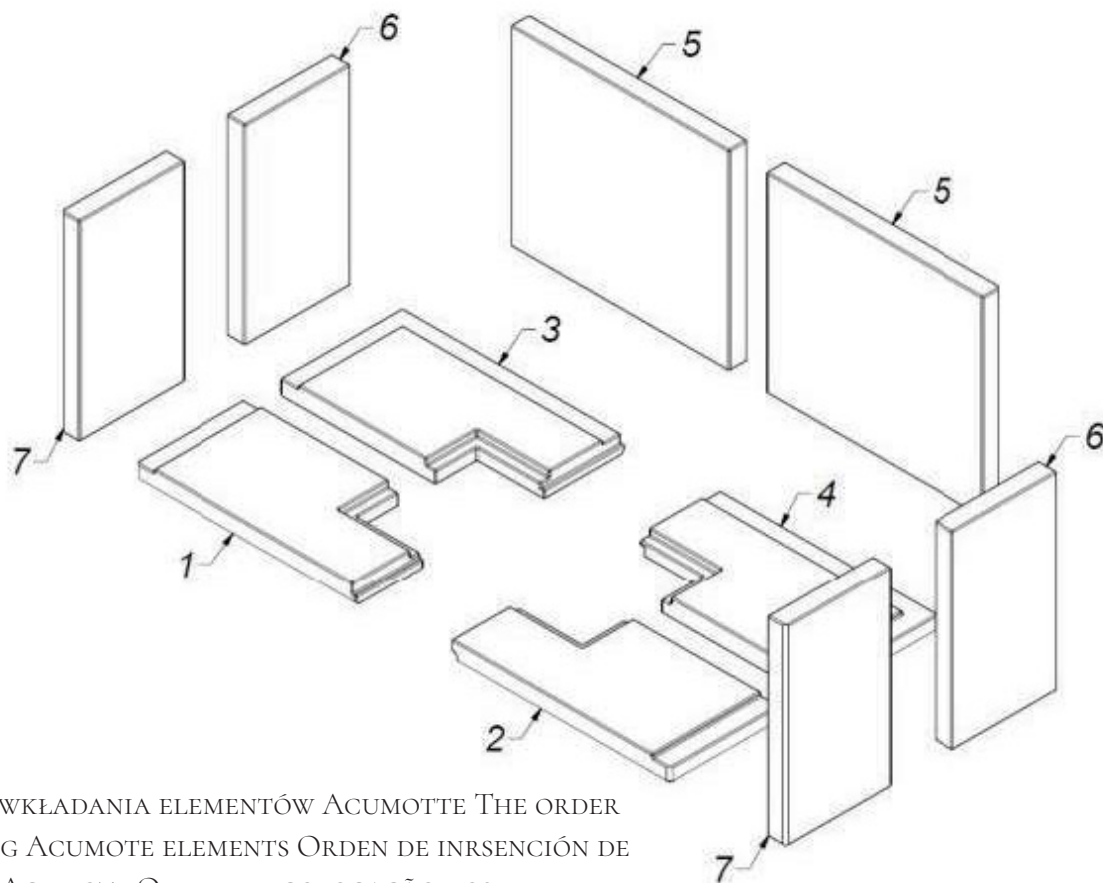
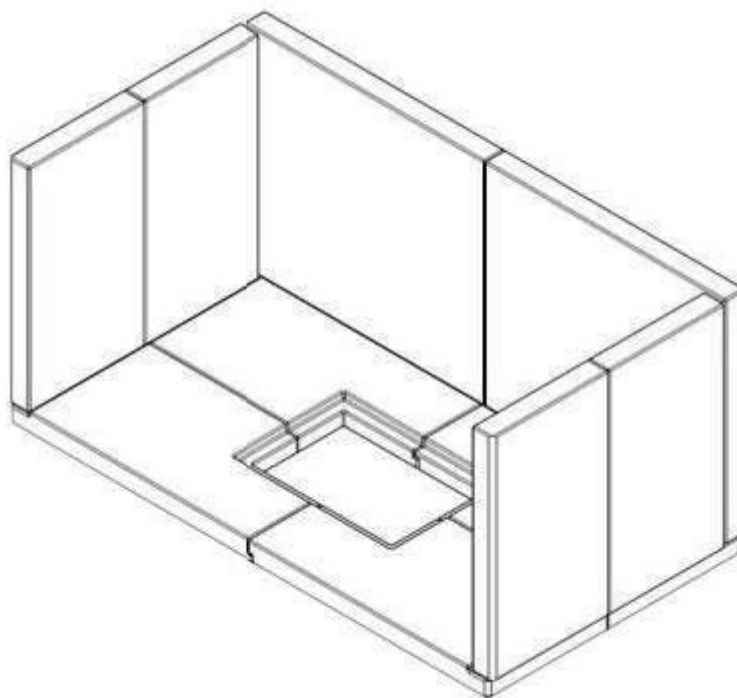

KOLEJNOŚĆ WKŁADANIA ELEMENTÓW ACUMOTTE THE ORDER OF INSERTING ACUMOTE ELEMENTS ORDEN DE INRSENCIÓN DE ELEMENTOS ACUMOTE ORDEM DE COLOCAÇÃO DOS ELEMENTOS ACUMOTTE REIHENFOLGE BEIM EINBAU VON ACCUMOTE PORADIE UMIESTNENIA PRVKOV ACUMOTTE ORDRE D'INSERTION DES ÉLÉMENTS DE L'ACUMOTTE L'ORDINE DI INSERIMENTO DEGLI ELEMENTI ACUMOTTE DE VOLGORDE VAN HET INVOEGEN VAN DE ACUMOTTE-ELEMENTEN ORDNINGEN FÖR ATT INFOGA ACUMOTTE-ELEMENTEN



KOLEJNOŚĆ WYJMOWANIA ELEMENTÓW ACUMOTTE THE  
 ORDER OF INSERTING ACUMOTE ELEMENTS ORDEN DE  
 ELIMINACIÓN ELEMENTOS ACUMOTE ORDEM DE  
 COLOCAÇÃO DOS ELEMENTOS ACUMOTTE REIHENFOLGE  
 BEIM AUSBÄU VON ACCUMOTE PORADIE  
 ODSTRAŇOVANIA PRVKOV ACUMOTTE ORDRE DE  
 RETRAIT DES ÉLÉMENTS DE L'ACUMOTTE L'ORDINE DI  
 RIMOZIONE DEGLI ELEMENTI ACUMOTTE  
 DE VOLGORDE VAN HET VERWIJDEREN VAN DE ACUMOTTE-ELEMENTEN  
 ORDNINGEN FÖR ATT TA BORT ACUMOTTE-ELEMENTEN

RYS. 14. KASETA ARKE - KOLEJNOŚĆ MONTAŻU I DEMONTAŻU ELEMENTÓW ACCUMOTE

FIG. 14. ARKE CASSETTE - THE ORDER OF ASSEMBLY AND DISASSEMBLY OF ACUMOTE COMPONENTS

FIG. 14. ARKE CASSETTE – ORDEN DE MONTAJE Y DESMONTAJE DE LOS COMPONENTES ACUMOTE

FIG. 14 - RECUPERADOR DE CALOR ARKE - A ORDEM DE MONTAGEM E DESMONTAGEM DOS COMPONENTES ACU-MOTTE

ABB. 14. ARKE KASSETTE – REIHENFOLGE BEI MONTAGE UND DEMONTAGE VON ACCUMOTE

OBR. 14. KAZETA ARKE - POSTUPNOST' MONTÁŽE A DEMONTÁŽE PRVKOV ACCUMOTE

FIG. 14 CASSETTE ARKE - SÉQUENCE DE MONTAGE ET DE DÉMONTAGE DES COMPOSANTS ACCUMOTE

FIG. 14. CASSETTA ARKE - SEQUENZA DI MONTAGGIO E SMONTAGGIO DEGLI ELEMENTI ACCUMOTE

FIGUUR 14. ARKE-CASSETTE - VOLGORDE VAN MONTAGE EN DEMONTAGE VAN ACCUMOTE-ELEMENTEN

FIG. 14. ARKE-KASSETT - SEKVENNS AV MONTERING OCH DEMONTERING AV ACCUMOTE-ELEMENT

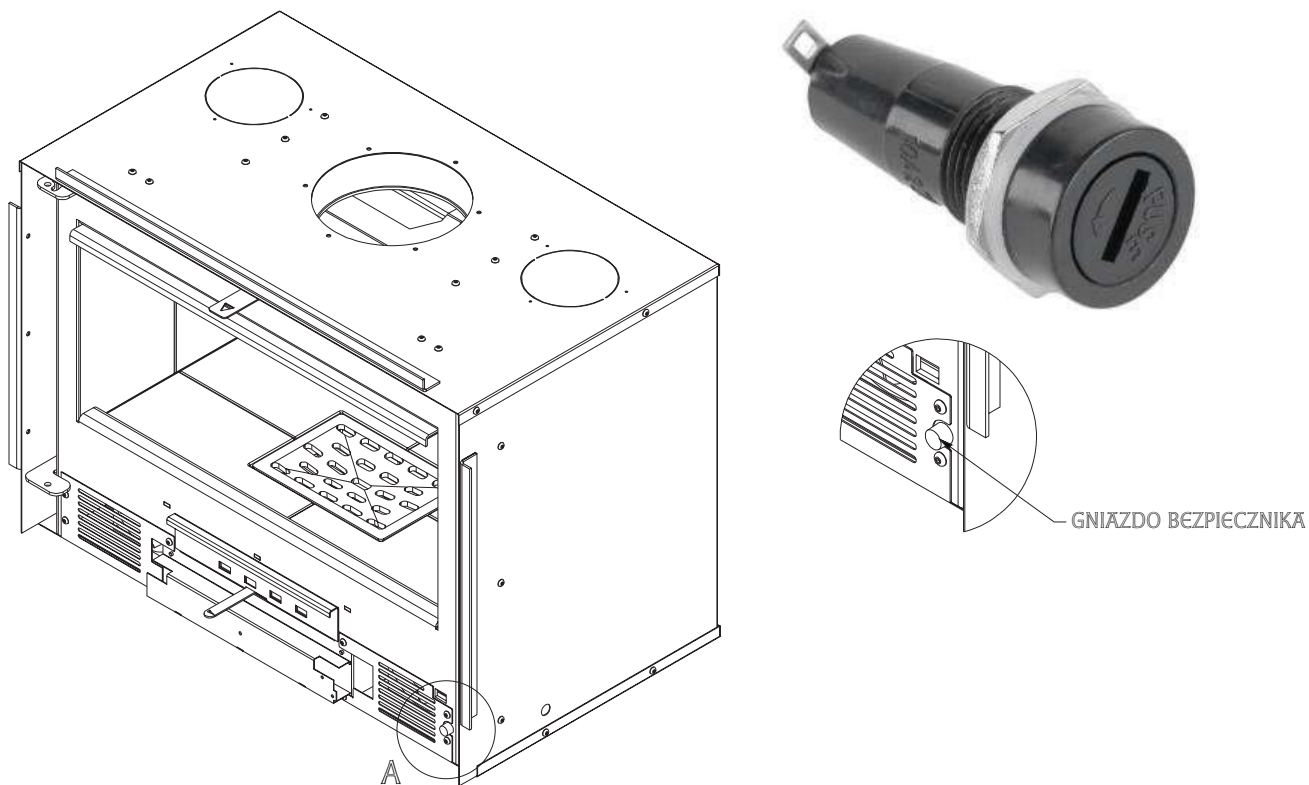

RYS 15. UMIEJSCAWIANIE GNIAZDA Z BEZPIECZNIKIEM WE WKŁADACH KOMINKOWYCH Z SERII ARKE

FIG. 15. ARKE CASSETTE - THE ORDER OF ASSEMBLY AND DISASSEMBLY OF ACUMOTE COMPONENTS

FIG. 15. UBICACIÓN DEL CASQUILLO CON FUSIBLE EN LA SERIE DE CHIMENEAS ARKE

FIG. 15 LOCALIZAÇÃO DA TOMADA COM FUSÍVEL NA SÉRIE DE LAREIRA ARKE

ABB. 15. LAGE DER STECKDOSE MIT SICHERUNG IN DER ARKE KAMINSERIE

OBRÁZOK 15. UMIESTNENIE DRŽIAKA POISTKY V KRBOVÝCH KACHLIACH ARKE

FIG. 15 : POSITIONNEMENT DU PORTE-FUSIBLE DANS LES POÊLES-CHEMINÉES DE LA SÉRIE ARKE

FIG. 15. POSIZIONAMENTO DELLA PRESA CON FUSIBILE NEGLI INSERTI PER CAMINI SERIE ARKE

AFB. 15. POSITIONERING VAN DE CONTACTDOOS MET ZEKERING IN DE ARKE-SERIE HAARDEN

FIG. 15. PLACERING AV UTTAGET MED EN SÄKRING I ARKE-SERIENS ELDSTADSINSATSER



KRATKI.PL MAREK BAL UL.  
GOMBROWICZA 4, WSOLA  
26-660 JEDLIŃSK, POLAND

TEL. 00 48 48 389 99 00

[WWW.KRATKI.COM](http://WWW.KRATKI.COM)

[WWW.FACEBOOK.COM/KRATKIPL](https://WWW.FACEBOOK.COM/KRATKIPL)

[WWW.YOUTUBE.COM/KRATKIPL](https://WWW.YOUTUBE.COM/KRATKIPL)

[WWW.INSTAGRAM.COM/KRATKIPL](https://WWW.INSTAGRAM.COM/KRATKIPL)



**EAC**

V14/AP/03/02/2025